

Dexterous Hand Micro Motor

CONTENTS

1. SAG-1565 Linear Actuator Motor	1
Planetary Gearhead + Coreless Brushed Motor + Planetary Roller Screw	
2. PG8K256-KS0816+SG35	2
8mm Planetary Gearbox + 8mm Coreless Brushed DC Motor + Lead Screw Nut Assembly	
3. PG10K28-KW1016+LG13175K20	3
10mm Planetary Gearbox+10mm Coreless Brushless Motor+Encoder-Driver Integrated Unit+Worm and Worm Gear Reducer Gearbox	
4. PG10K28-KW1016+LG04M17Z (Actuator 1)	4
10mm Planetary Gearbox+10mm Coreless Brushless Motor+Worm and Worm Gear Reducer Gearbox	
5. PG10K28-KW1317+LG13175K20	5
10mm Planetary Gearbox+13mm Coreless Brushless Motor+Encoder-Driver Integrated Unit+Worm and Worm Gear Reducer Gearbox	
6. PG10K28-KW1317+LG04M20Z (Actuator 3)	6
10mm Planetary Gearbox+13mm Coreless Brushless Motor+Worm and Worm Gear Reducer Gearbox	

7. TSL-PG10K28-KW1016-WG03M	7
10 mm Planetary Gearbox + 10 mm Coreless Brushless Motor +Encoder + Worm-Gear Reducer	
8. TSL-13P1317RB-25+LG04M20Z	8
13 mm Planetary Gear Reducer + 13 mm Coreless Brushless Motor +Worm-Gear Gearbox	
9. TSL-PG13K100-KW1317+MA1024	9
13mm Planetary Gearbox + 13mm Coreless Brushless Motor + Encoder	
10. PG10K28-KW1317+LG1598K20	10
10mm planetary gearbox + 13mm coreless brushless motor + integrated encoder and driver + worm gearbox	
11. PG10K28-KW1016+LG1598K20	11
10mm Planetary Gearbox + 10mm Coreless Brushless Motor + Integrated Encoder & Drive + Worm Gearbox	
12. TSL-PG13K25-KW1317-SG04+MA1024	12
13mm Planetary Gearbox + 13mm Coreless Brushless Motor+T-type lead screw + Encoder	
13. TSL-12P1220R-36+MA512-17.2	13
12 mm Planetary Gearbox + 12 mm Coreless Brushed Motor Incremental Encoder	

14. TSL-PG10K28-KW1317+LG04M20Z	14
10mm Planetary Gearbox + 13mm Coreless Brushless Motor+Worm Gear Reducer + Drive	
15. TSL-PG13K125-KW1327	15
13mm Planetary Gearbox + 13mm Coreless Brushless Motor	
16. TSL-PG13K125-KW1327+MA1024	16
13mm Planetary Gearbox + 13mm Coreless Brushless Motor+Magnetic Encoder	
17. TSL-PG13K256-KW1317	17
13mm Planetary Gearbox + 13mm Coreless Brushless Motor	
18. PG16K29-KW1624+LG04K20	18
16mm Planetary Gearbox + 16mm Coreless Brushless Motor + Worm Gear Output	
19. TSL-PG16K128-KW1618+LG04M20Z (Thumb Grasp Motor Module)	19
16mm Planetary Gearbox+16mm Coreless Brushless Motor+worm gear reverse output	
20. TSL-PG16K128-KW1618+LG04M20Z (Actuator 4)	20
16mm Planetary Gearbox+16mm Coreless Brushless Motor+worm gear reverse output	

21. TSL-PG16K128-KW1618+LG04M20Z (Actuator 2)	21
16mm Planetary Gearbox + 16mm Coreless Brushless Motor + worm gear reverse output	
22. TSL-PG16K84-KW1630	22
16mm Planetary Gearbox + 16mm Coreless Brushless Motor	
23. PG10K326-KS1022 (Round threaded hole)	23
10 mm planetary gearbox + 10 mm coreless brushed motor	
24. TSL-10P1022R-77	24
10mm Coreless Brushed Motor with 10mm Planetary Gearbox	
25. TSL-16P1625R-16	25
16 mm Planetary Gearbox + 16 mm Coreless Brushed Motor	
26. TSL-16P1625R-53	26
16 mm Planetary Gearbox + 16mm Coreless Brushed Motor	
27. TSL-16P1640R-16	27
16 mm Planetary Gearbox + 16mm Coreless Brushed Motor	

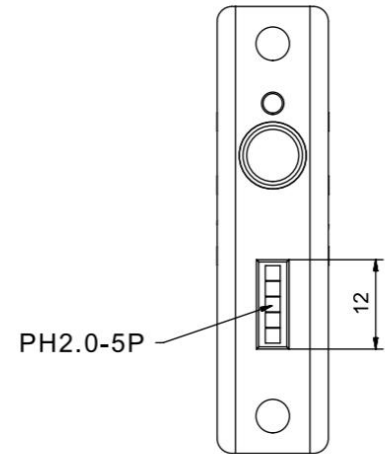
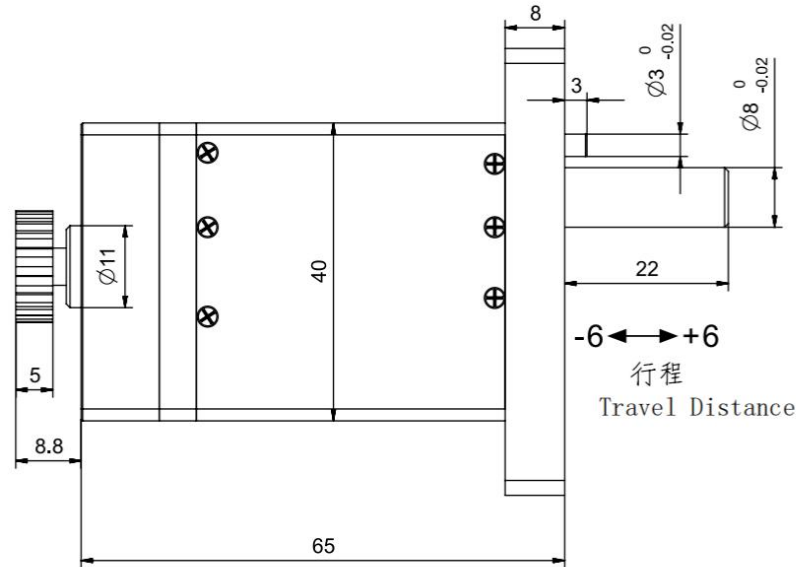
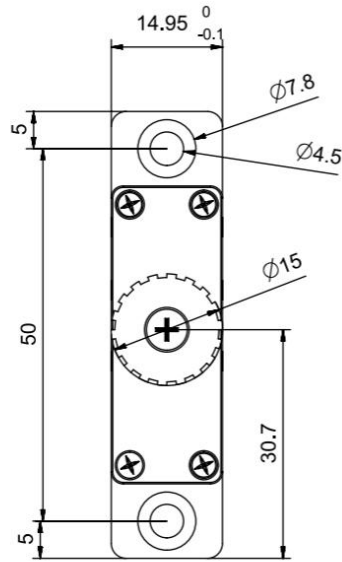

Foldback Linear Actuator Motor Parameters

1. Rated Voltage:12V
2. Rated Current:800 mA
3. Peak Current:≥ 2 A
4. Operating Temperature: -10 to 60°C
5. Actuator Stroke:12 mm
6. Rated Push/Pull Force:300N
7. Maximum Push/Pull Force:500N
8. Actuator No-Load Speed:≥ 0.4 mm/s
9. Actuator Repeat Positioning Accuracy:± 3 μm
10. With Absolute Value Feedback
11. Communication Interface:RS485
12. Output Terminal Interface:PH2.0-5P

Motor Performance Parameters

1. Motor Type: Coreless Brushed Motor
2. Operating Voltage: 12V
3. No-Load Speed: 22000 ± 10% RPM
4. No-Load Current: ≤ 40 mA
5. Load Speed: 20000 ± 10% RPM
6. Load Torque: ≥ 11 g·cm
7. Load Current: ≤ 0.3 A
8. Stall Torque: ≥ 120 g·cm
9. Stall Current: ≤ 3 A
10. Number of Pole Pairs:1 pole pair
11. Operating Temperature:-40 to 85°C
12. Noise: ≤ 45 dB
13. Maximum Motor Efficiency:75%

Geared Motor Performance Parameters

1. Operating Voltage:12V
2. No-Load Speed: 60 ± 10% RPM
3. No-Load Current: ≤ 0.2 A
4. Load Speed: 50 ± 10% RPM
5. Load Torque: ≥ 0.24 N·m
6. Load Current: ≤ 0.5 A
7. Operating Temperature: -20 to 100°C
8. Gear Reduction Ratio: 1:371.425
(Planetary 1:25; Gear Set 1:14.857)
9. Noise: ≤ 55 dB
10. Gearbox Material: Pure Steel
(Machined)

设计

审核

批准

日期

2026.05.06

第一视觉画法

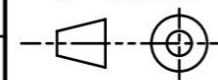

未注线性与角度尺寸公差：
GB/T1804-m eqv
ISO 2768-1:m

Planetary Gearhead + Coreless Brushed Motor +
Planetary Roller Screw

(产品类型)

SAG-1565 Linear Actuator Motor

(产品型号)

Tsinglin Micro Motors Limited

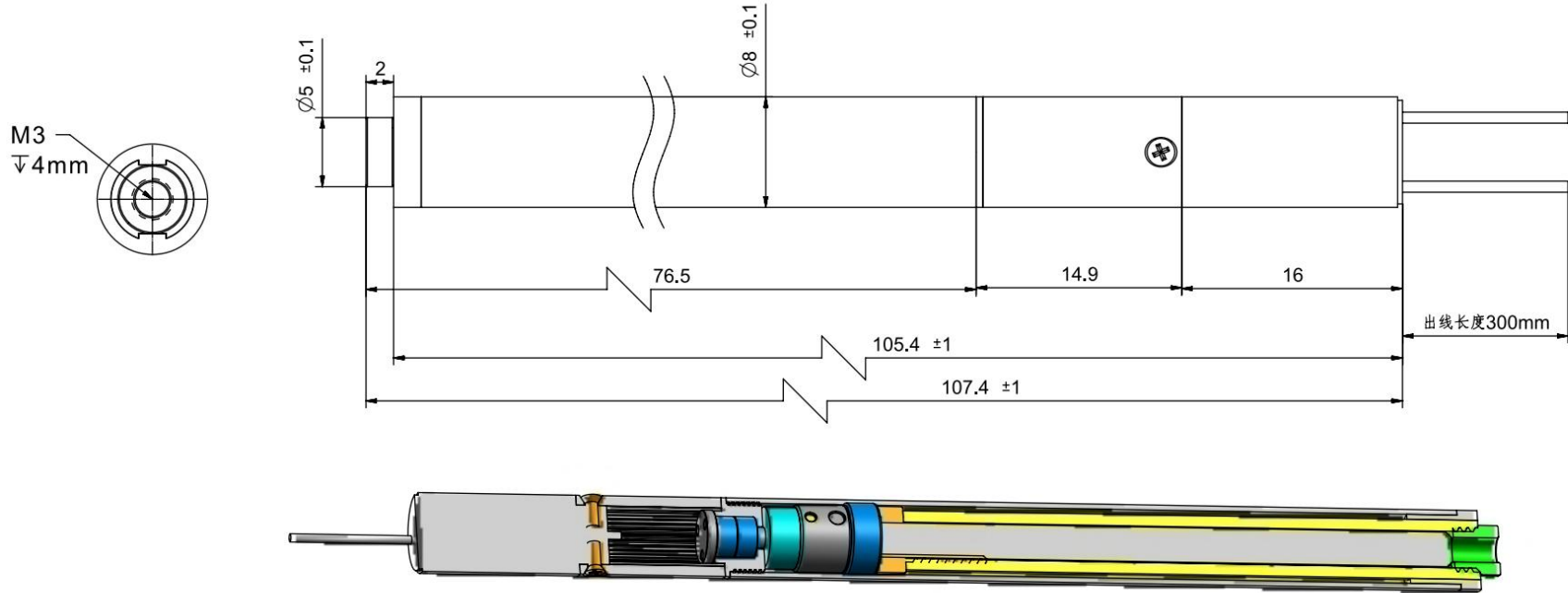

Motor Wiring Sequence:
 PIN1-2
 Pin 1: VCC, Red Wire (Positive Pole)
 Pin 2: GND, Blue Wire (Negative Pole)

T-type Lead Screw Gear Motor Parameters

Lead Screw Material: 304 Stainless Steel
 Nut Material: Brass
 Diameter: 3.5 mm
 Number of Thread Starts: 2 Starts
 Pitch: 1.2 mm
 Lead: 2.4 mm
 Hand of Thread: Right-hand
 Total Stroke: 50 mm
 Lead Screw Nut Output Thrust: 30 N
 No-load Output Speed: 3 ± 10% mm/s
 Rated Output Speed: 2.5 ± 10% mm/s

<p>Motor Performance Parameters</p> <p>Motor Type: Coreless Brushed DC Motor Operating Voltage: 7.4 V No-load Speed: 20000 ± 10% RPM No-load Current: ≤ 0.08 A Load Speed: 15000 ± 10% RPM Load Torque: ≥ 5 g·cm Load Current: ≤ 0.15 A Pole Pairs: 1 Pair of Poles Operating Temperature: -40 ~ 125 °C Noise Level: ≤ 40 dB Maximum Motor Efficiency: 60%</p>	<p>Planetary Gear Motor Performance Parameters</p> <p>Operating Voltage: 7.4 V No-load Speed: 80 ± 10% RPM No-load Current: ≤ 0.1 A Load Speed: 60 ± 10% RPM Load Torque: ≥ 500 g·cm Load Current: ≤ 0.2 A Operating Temperature: -40 ~ 125 °C Gear Ratio: 1:256 Noise Level: ≤ 55 dB Gearbox Material: Solid Steel (Machined)</p>
---	--

设计		第一视觉画法	8mm Planetary Gearbox + 8mm Coreless Brushed DC Motor + Lead Screw Nut Assembly (Motor Type)
审核			PG8K256-KS0816+SG35 (Motor Model)
批准	2025.05.14	未注线性与角度尺寸公差： GB/T1804-m eqv ISO 2768-1:m	Tsinglin Micro Motors Limited
日期			

Worm and Worm Gear Parameter Table		
	Worm	Worm Gear
Module	0.4	
Number of Starts/ Number of Teeth	1	20
Pressure Angle	20°	20°
Tip Diameter	5	8.8
Reference Diameter	4.2	8
Lead Angle	Right-hand 5.44°	
Worm Lead	1.257	-
Worm Pitch	1.257	-
Addendum Coefficient	1	1
Clearance Coefficient	0.25	0.25
Modification Coefficient	-	-
Transmission Center Distance	6.1	
Material	20crmnti	
Accuracy Class	GB/T 10095-2001 - Grade 8	

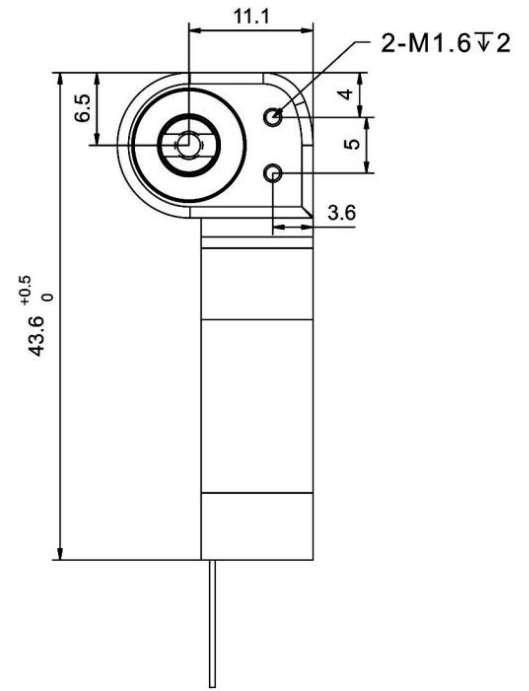
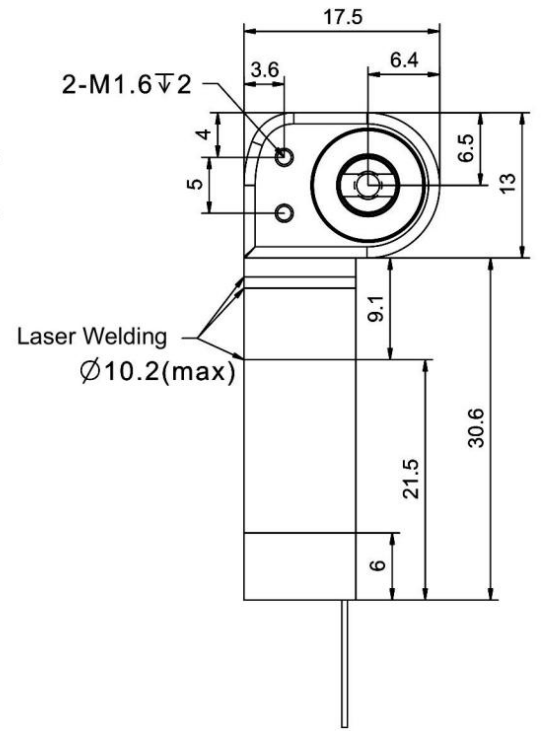
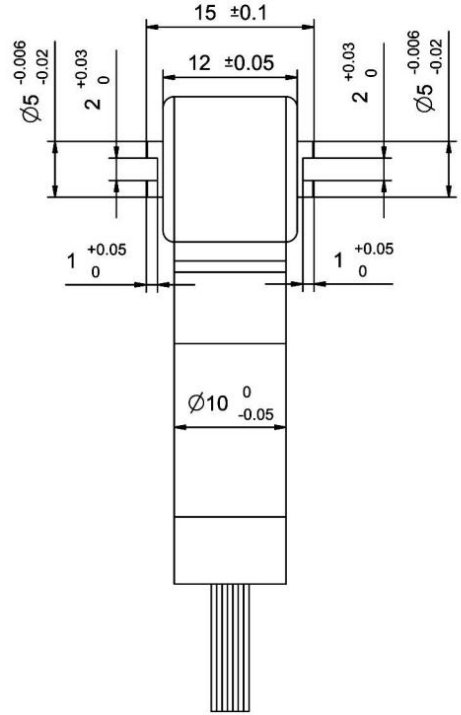

Motor Performance Parameters:

1. Motor Type: Coreless Brushless Motor
2. Operating Voltage: 12V
3. No-load Speed: 32000 ±10% RPM
4. No-load Current: ≤0.15A
5. Rated Speed: 18000 ±10% RPM
6. Rated Torque: ≥10 g.cm
7. Rated Current: ≤0.5A
8. Pole Pairs: 2 Pole Pairs
9. Operating Temperature: -40-85°C
10. Noise: ≤45 DB
11. Motor Maximum Efficiency: 75%

Gearmotor Performance Parameters:

1. Operating Voltage: 12V
2. No-load Speed: 55 ±10% RPM
3. No-load Current: ≤0.2A
4. Rated Speed: 35 ±10% RPM
5. Rated Torque: ≥800 g.cm
6. Rated Current: ≤0.5A
7. Operating Temperature: -40-80°C
8. Reduction Ratio: 1:560
(Planetary Stage 1:28, Worm and Worm Gear Stage 1:20)
9. Noise: ≤55 DB
10. Gearbox Material: Pure Steel
(Machined)

Encoder + Driver: pin1-4 wire
 pin1:VDD
 pin2:GND
 pin3:RXD
 pin4:TXD

Design		First Angle Projection 	10mm Planetary Gearbox+10mm Coreless Brushless Motor+Encoder-Driver Integrated Unit+Worm and Worm Gear Reducer Gearbox (Product Type)
Reviewed			PG10K28-KW1016+LG13175K20 (Product Model)
Approved		General tolerances for untoleranced linear and angular dimensions: GB/T 1804-m eqv ISO 2768-1:m	Tsinglin Micro Motors Limited
Date			

Worm and Worm Gear Parameter Table		
	Worm	Worm Gear
Module	0.4	
Number of Starts/ Number of Teeth	1	17
Pressure Angle	20°	20°
Tip Diameter	5	7.6
Reference Diameter	4.2	6.8
Lead Angle	Right-hand 5.44°	
Worm Lead	1.257	-
Worm Pitch	1.257	-
Addendum Coefficient	1	1
Clearance Coefficient	0.25	0.25
Modification Coefficient	-	-
Transmission Center Distance	5.55	
Material	SUS416	20crmnti
Accuracy Class	GB/T 10095-2001 - Grade 8	

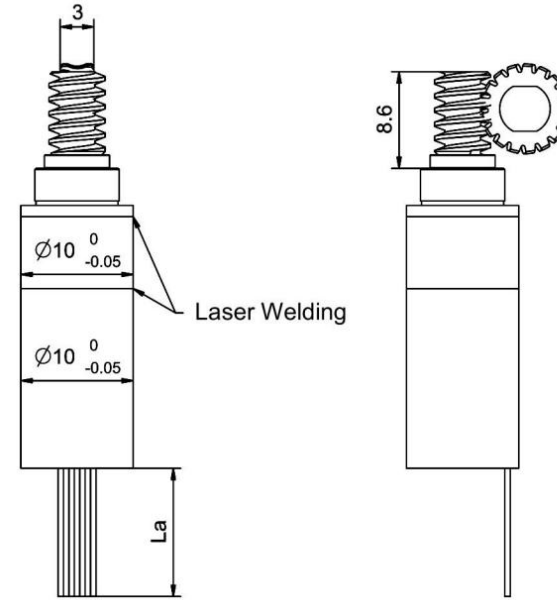
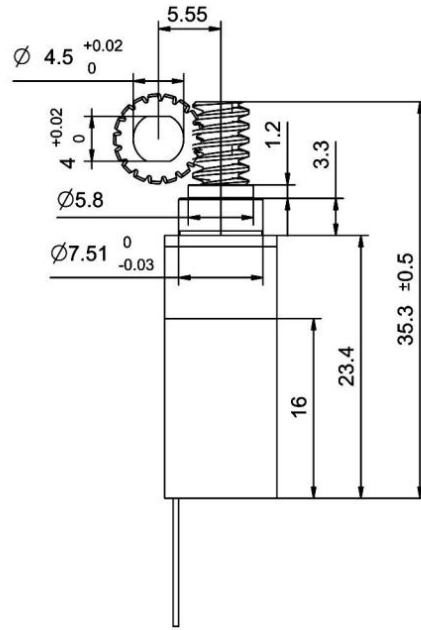

FPC Harness
Length La:
70mm



Coreless Brushless Motor:
FPC: 0.5mm-12P
Pin Assignment: PIN1-12
pin1-HALL A
pin2-HALL B
pin3-HALL Z
pin4-3.3V
pin5-GND
pin6+7-Motor U
pin8+9-Motor V
pin10+11-Motor W
pin12-Temp. Ctrl.

Motor Performance Parameters:

1. Motor Type: Coreless Brushless Motor
2. Operating Voltage: 12V
3. No-load Speed: 32000 ±10% RPM
4. No-load Current: ≤0.4A
5. Rated Speed: 20000 ±10% RPM
6. Rated Torque: ≥10 g.cm
7. Rated Current: ≤0.6A
8. Pole Pairs: 2 Pole Pairs
9. Operating Temperature: -40-85°C
10. Noise: ≤45 DB
11. Motor Maximum Efficiency: 75%

Gearmotor Performance Parameters:

1. Operating Voltage: 12V
2. No-load Speed: 65 ±10% RPM
3. No-load Current: ≤0.3A
4. Rated Speed: 40 ±10% RPM
5. Rated Torque: ≥0.25NM
6. Rated Current: ≤0.6A
7. Peak Torque (2s): 0.6 N.m
8. Peak Current: ≤1A
9. Operating Temperature: -40-80°C
10. Reduction Ratio: 1:476
(Planetary Stage 1:28, Worm and Worm Gear Stage 1:17)
11. Worm and Worm Gear Self-locking Torque: ≥2 NM
12. Noise: ≤55 DB
13. Gearbox Material: Pure Steel (Machined)

Design		First Angle Projection	10mm Planetary Gearbox+10mm Coreless Brushless Motor+Worm and Worm Gear Reducer Gearbox (Product Type)
Reviewed			
Approved		General tolerances for untoleranced linear and angular dimensions: GB/T 1804-m eqv ISO 2768-1:m	PG10K28-KW1016+LG04M17Z (Actuator 1) (Product Model)
Date	2026.01.20		Tsinglin Micro Motors Limited

Worm and Worm Gear Parameter Table

	Worm	Worm Gear
Module	0.4	
Number of Starts/ Number of Teeth	1	20
Pressure Angle	20°	20°
Tip Diameter	5	8.8
Reference Diameter	4.2	8
Lead Angle	Right-hand 5.44°	
Worm Lead	1.257	-
Worm Pitch	1.257	-
Addendum Coefficient	1	1
Clearance Coefficient	0.25	0.25
Modification Coefficient	-	-
Transmission Center Distance	6.1	
Material	20crmnti	
Accuracy Class	GB/T 10095-2001 - Grade 8	

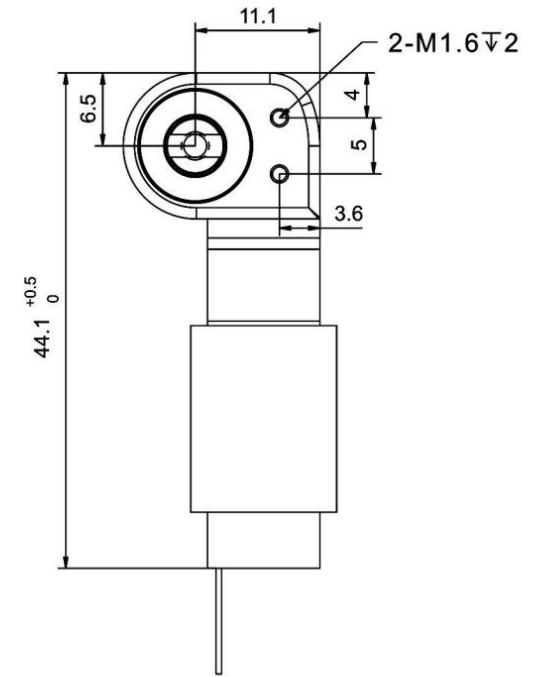
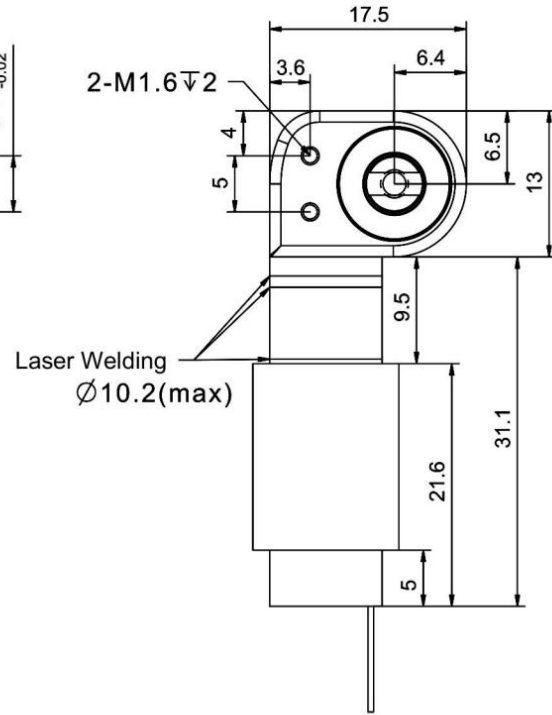
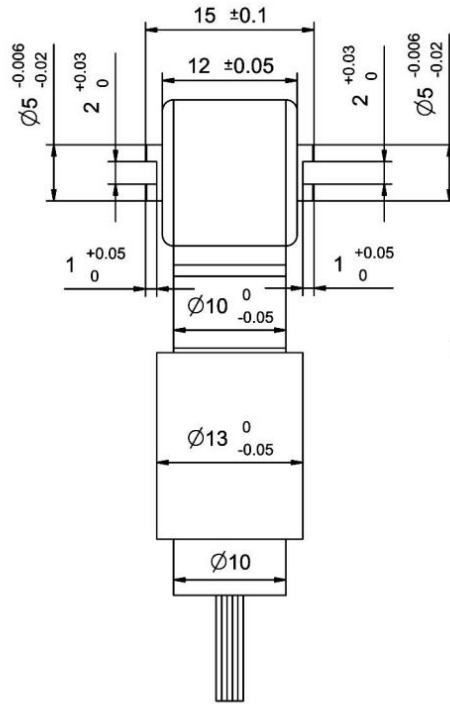

Motor Performance Parameters:

1. Motor Type: Coreless Brushless Motor
2. Operating Voltage: 12V
3. No-load Speed: 25000 ±10% RPM
4. No-load Current: ≤0.4A
5. Load Speed: 18000 ±10% RPM
6. Load Torque: ≥15 g.cm
7. Load Current: ≤1A
8. Stall Torque: ≥100 g.cm
9. Pole Pairs: 2 Pole Pairs
10. Operating Temperature: -40-85°C
11. Noise: ≤45 DB
12. Motor Maximum Efficiency: 75%

Gearmotor Performance Parameters:

1. Operating Voltage: 12V
2. No-load Speed: 45 ±10% RPM
3. No-load Current: ≤0.5A
4. Rated Speed: 30 ±10% RPM
5. Rated Torque: ≥2500 g.cm
6. Rated Current: ≤1.2A
7. Operating Temperature: -40-80°C
8. Reduction Ratio: 1:560
(Planetary Stage 1:28, Worm and Worm Gear Stage 1:20)
9. Noise: ≤55 DB
10. Gearbox Material: Pure Steel
(Machined)

Encoder + Driver: pin1-4 wire

- pin1:VDD
- pin2:GND
- pin3:RXD
- pin4:TXD

Design		First Angle Projection 	10mm Planetary Gearbox+13mm Coreless Brushless Motor+Encoder-Driver Integrated Unit+Worm and Worm Gear Reducer Gearbox (Product Type)
Reviewed			PG10K28-KW1317+LG13175K20 (Product Model)
Approved		General tolerances for untoleranced linear and angular dimensions: GB/T 1804-m eqv ISO 2768-1:m	Tsinglin Micro Motors Limited
Date			

Worm and Worm Gear Parameter Table		
	Worm	Worm Gear
Module	0.4	
Number of Starts/ Number of Teeth	1	20
Pressure Angle	20°	20°
Tip Diameter	5	8.8
Reference Diameter	4.2	8
Lead Angle	Right-hand 5.44°	
Worm Lead	1.257	-
Worm Pitch	1.257	-
Addendum Coefficient	1	1
Clearance Coefficient	0.25	0.25
Modification Coefficient	-	-
Transmission Center Distance	6.1	
Material	SUS416	20crmnti
Accuracy Class	GB/T 10095-2001 - Grade 8	

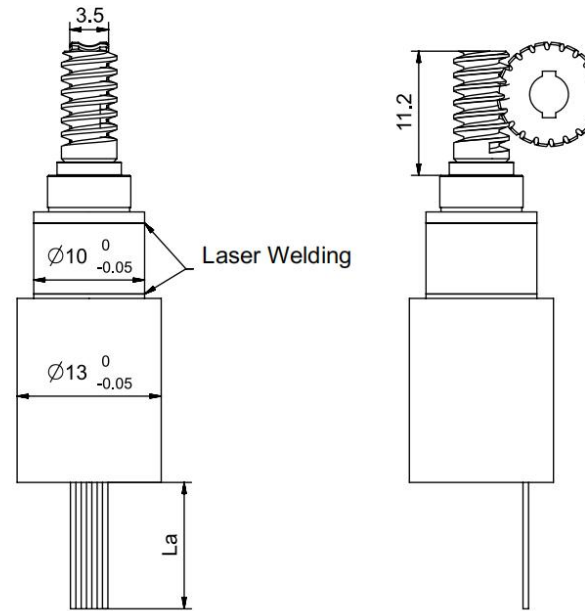
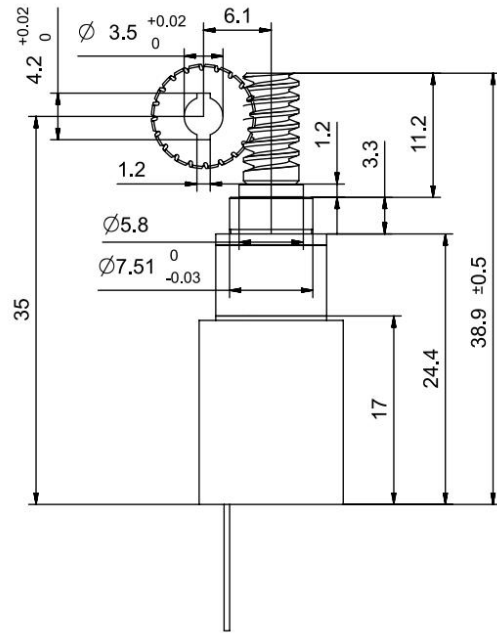

- Motor Performance Parameters:**
1. Motor Type: Coreless Brushless Motor
 2. Operating Voltage: 12V
 3. No-load Speed: 30000 ±10% RPM
 4. No-load Current: ≤0.4A
 5. Rated Speed: 23000 ±10% RPM
 6. Rated Torque: ≥3mN.m
 7. Rated Current: ≤1.5A
 8. Pole Pairs: 2 Pole Pairs
 9. Operating Temperature: -40-85°C
 10. Noise: ≤45 DB
 11. Motor Maximum Efficiency: 75%

Gearmotor Performance Parameters:

1. Operating Voltage: 12V
2. No-load Speed: 50 ±10% RPM
3. No-load Current: ≤0.4A
4. Rated Speed: 40 ±10% RPM
5. Rated Torque: ≥0.75NM
6. Rated Current: ≤1.5A
7. Peak Torque (2s): 1.5 N.m
8. Peak Current: ≤2.5A
9. Operating Temperature: -40-80°C
10. Reduction Ratio: 1:560
(Planetary Stage 1:28, Worm and Worm Gear Stage 1:20)
11. Worm and Worm Gear Self-locking
Torque: ≥3 NM
12. Noise: ≤55 DB
13. Gearbox Material: Pure Steel
(Machined)

FPC Harness
Length La:
70mm



Coreless Brushless Motor:
FPC: 0.5mm-12P
Pin Assignment: PIN1-12
pin1-HALL A
pin2-HALL B
pin3-HALL Z
pin4-3.3V
pin5-GND
pin6+7-Motor U
pin8+9-Motor V
pin10+11-Motor W
pin12-Temp. Ctrl.

Design	First Angle Projection	10mm Planetary Gearbox+13mm Coreless Brushless Motor+Worm and Worm Gear Reducer Gearbox (Product Type)
Reviewed		
Approved	General tolerances for untoleranced linear and angular dimensions: GB/T 1804-m eqv ISO 2768-1:m	PG10K28-KW1317+LG04M20Z (Actuator 3) (Product Model)
Date	2026.01.20	Tsinglin Micro Motors Limited

Worm and Worm Gear Parameter Table		
	Worm	Worm Gear
Module	0.4	
Number of Starts / Teeth	1	20
Pressure Angle	20°	20°
Addendum Circle Diameter	5	8.8
Pitch Circle Diameter	4.2	8
Lead Angle	Right-hand 5.44°	
Addendum Coefficient	1	1
Clearance Coefficient	0.25	0.25
Modification Coefficient	-	-
Material	SUS416	
Accuracy Grade	GB/T 10095-2001, Grade 8	

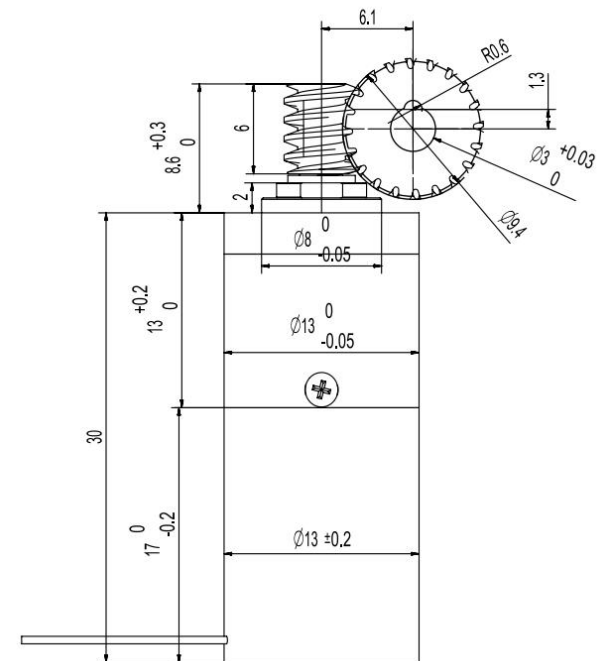
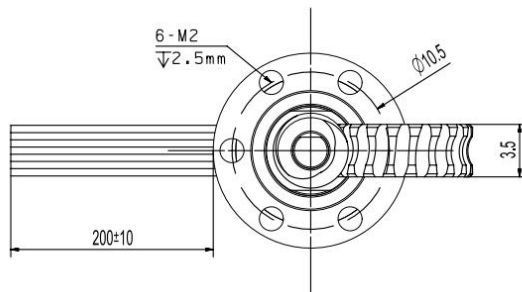

Motor Performance Specifications:

1. Motor Type: Coreless Brushless Motor
2. Operating Voltage: 12V
3. No-load Speed: 25,000 ± 10% RPM
4. No-load Current: ≤ 0.2 A
5. Load Speed: 18,000 ± 10% RPM
6. Load Torque: ≥ 15 g·cm
7. Load Current: ≤ 0.8 A
8. Stall Torque: ≥ 100 g·cm
9. Number of Pole Pairs: 2 pole pairs
10. Operating Temperature: -40 to 85°C
11. Weight: ≤ 30 g
12. Noise Level: ≤ 45 dB
13. Maximum Motor Efficiency: 75%

Reducer Motor Performance Specifications:

1. Operating Voltage: 12V
2. No-load Speed: 50 ± 10% RPM
3. No-load Current: ≤ 0.3 A
4. Load Speed: 35 ± 10% RPM
5. Load Torque: ≥ 0.4 N·m
6. Load Current: ≤ 1 A
7. Stall Torque: ≥ 3 N·m
8. Operating Temperature: -40 to 80°C
9. Gear Reduction Ratio: 1:500 (Planetary: 1:25, Worm Gear: 1:20)
10. Noise Level: ≤ 55 dB
11. Gearbox Material: Pure Copper (Machined)

**Coreless Brushless Motor
Hall Sensor Pin Assignment: PIN1-8**

- pin1 -U (Purple)
- pin2 -V (Brown)
- pin3 -W (White)
- pin4 - +5V (Red)
- pin5 -GND (Black)
- pin6 -HALL_U (Yellow)
- pin7 -HALL_V (Green)
- pin8 -HALL_W (Blue)

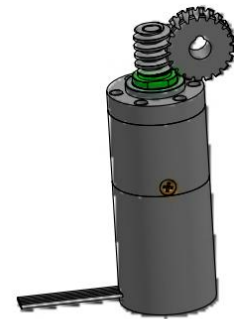

Design		First-Angle Projection Method	13 mm Planetary Gear Reducer + 13 mm Coreless Brushless Motor +Worm-Gear Gearbox (Product Type)
Review			
Approval		Unspecified Linear and Angular Dimension Tolerances: GB/T 1804-m eqv ISO 2768-1:m	TSL-13P1317RB-25+LG04M20Z (Product Model)
Date	2025.03.21		Tsinglin Micro Motors Limited

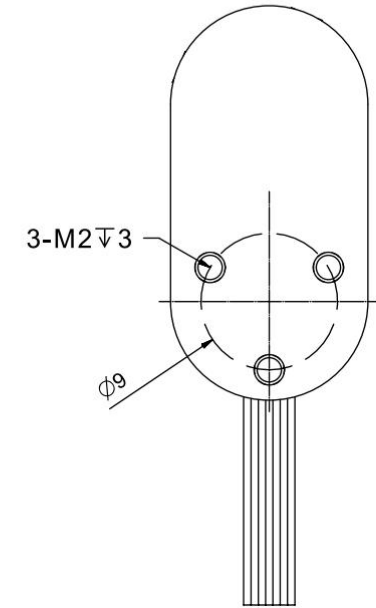
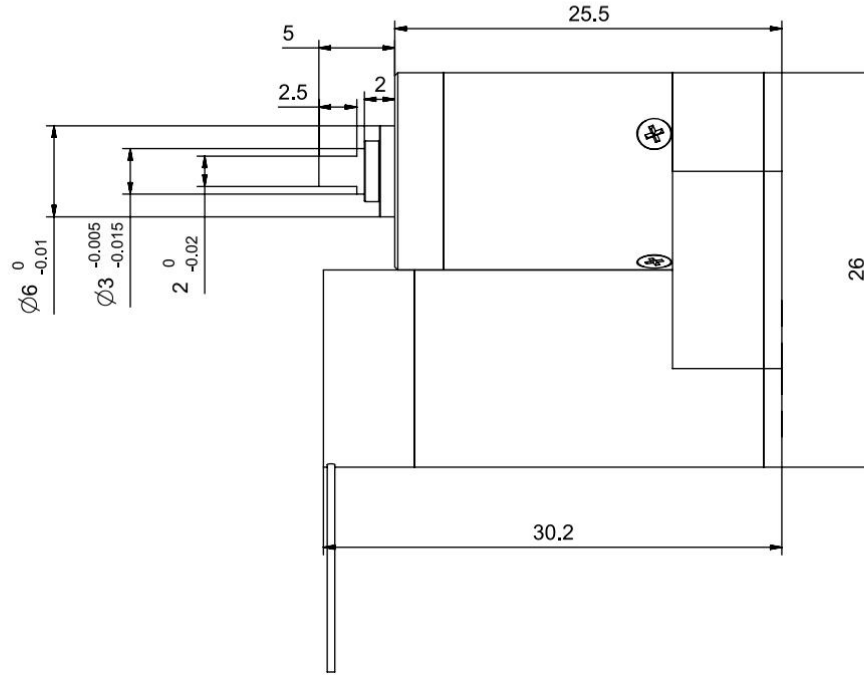
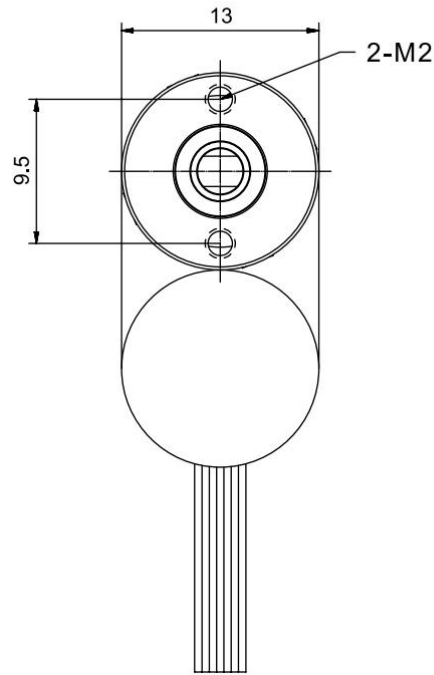

Motor Performance Parameters:

1. Motor Type: Coreless Brushless Motor
2. Operating Voltage: 12V
3. No-load Speed: 25000±10%RPM
4. No-load Current: ≤0.2A
5. Load Speed: 18000±10%RPM
6. Load Torque: ≥15g.cm
7. Load Current: ≤0.8A
8. Stall Torque: ≥100g.cm
9. Pole Pairs: 2 Pole Pairs
10. Operating Temperature: -40-85°C
11. Weight: ≤30g
12. Noise: ≤45DB
13. Motor Maximum Efficiency: 75%

Gearmotor Performance Parameters:

1. Operating Voltage: 12V
2. No-load Speed: 250±10%RPM
3. No-load Current: ≤0.3A
4. Rated Speed: 180±10%RPM
5. Rated Torque: ≥0.08NM
6. Rated Current: ≤1A
7. Stall Torque: ≥0.5 Nm
8. Operating Temperature: -40-80°C
9. Reduction Ratio: 1:100
10. Noise: ≤55DB
11. Gearbox Material: Pure Steel (Machined)

Coreless Brushless Motor

Wiring Sequence: PIN1-3

- pin1 - U (White)
- pin2 - V (Yellow)
- pin3 - W (Blue)

Encoder Wiring Sequence: PIN1-5

- pin1 - GND (Black)
- pin2 - VCC (Red)
- pin3 - A± (Single-ended) (Yellow)
- pin4 - B± (Single-ended) (Green)
- pin5 - Z± (Single-ended) (Blue)

Note: Magnetic encoder, digital output, 3 channels, 1024 PPR

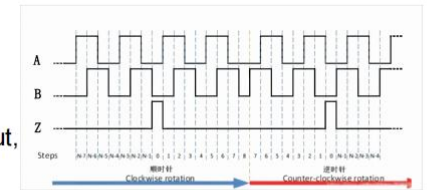

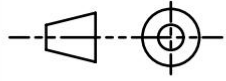
设计		第一视觉画法  未注线性与角度尺寸公差： GB\T1804-m eq v ISO 2768-1:m
审核		
批准		
日期	2025.11.15	

13mm Planetary Gearbox + 13mm Coreless Brushless Motor + Encoder (Product Type)
TSL-PG13K100-KW1317+MA1024 (Inverted Module) (Product Model)
Tsinglin Micro Motors Limited

Worm and Worm Gear Parameter Table

Parameter	Worm	Worm Gear
Module	0.3	
Number of Threads / Teeth	1	20
Pressure Angle	20° C	20° C
Addendum Circle Diameter	4.5	6.6
Pitch Circle Diameter	3.9	6
Lead Angle	Right-hand 4.51°	
Worm Lead	0.942	-
Worm Pitch	0.942	-
Addendum Coefficient	1	1
Clearance Coefficient	0.25	0.25
Modification Coefficient	-	-
Center Distance	4.95	
Material	20 crmnti	
Accuracy Grade	GB/T 10095-2001 Grade 8	

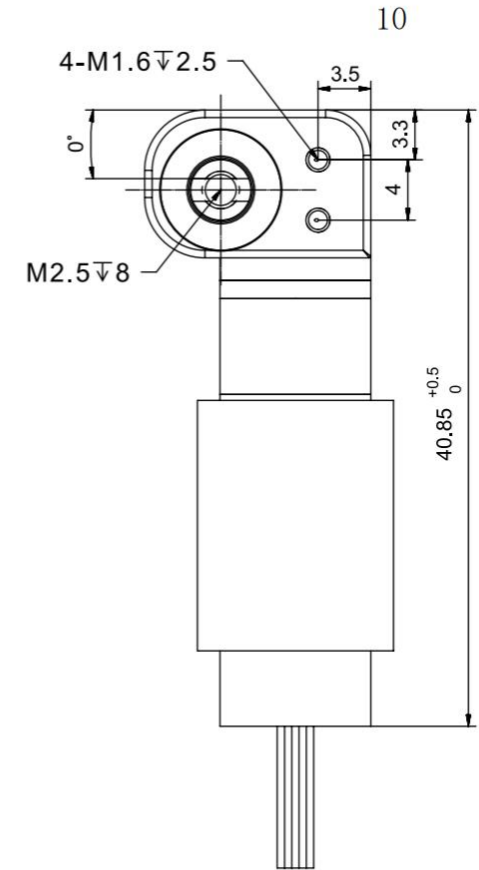
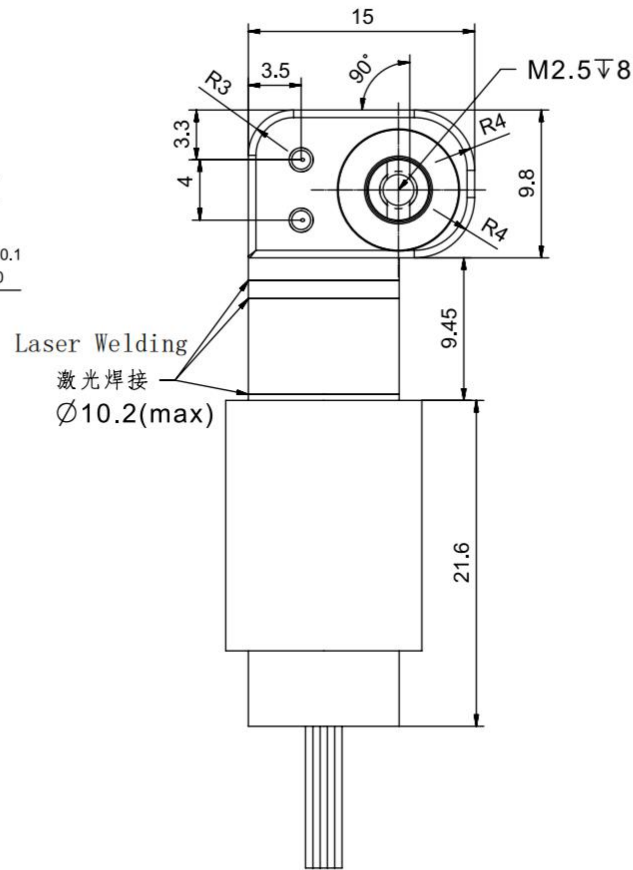
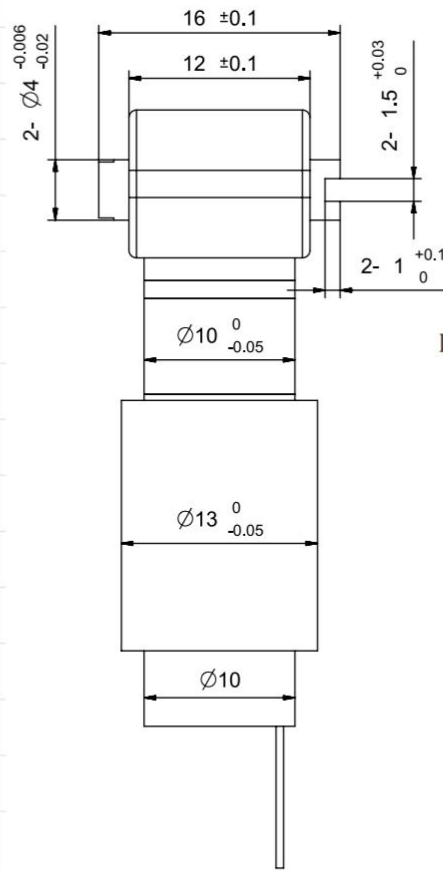

Motor Performance Parameters

1. Motor Type: Coreless Brushless Motor (BLDC)
2. Operating Voltage: 12V
3. No-Load Speed: 25000 ± 10% RPM
4. No-Load Current: ≤ 0.4A
5. Rated Speed / Load Speed: 18000 ± 10% RPM
6. Rated Torque / Load Torque: ≥ 15 g.cm
7. Rated Current / Load Current: ≤ 1A
8. Stall Torque: ≥ 100 g.cm
9. Number of Pole Pairs: 2 Pole Pairs (4 Poles)
10. Operating Temperature: -40 to 85°C
11. Acoustic Noise: ≤ 45dB
12. Maximum Efficiency: 75%

Geared Motor Performance Parameters

1. Operating Voltage: 12V
2. No-Load Speed: 45 ± 10% RPM
3. No-Load Current: ≤ 0.5A
4. Rated Speed: 30 ± 10% RPM
5. Rated Torque: ≥ 2500 g.cm
6. Rated Current: ≤ 1.2A
7. Operating Temperature: -40 to 80°C
8. Gear Ratio: 1:560
(Planetary stage 1:28, Worm stage 1:20)
9. Acoustic Noise: ≤ 55dB
10. Gearbox Material: Machined Steel
(Pure steel)

Encoder + Drive: Pin 1-4 Wires
 Pin 1: VDD (Power Supply)
 Pin 2: GND (Ground)
 Pin 3: RXD (Receive Data)
 Pin 4: TXD (Transmit Data)

设计		第一视觉画法 	10mm planetary gearbox + 13mm coreless brushless motor + integrated encoder and driver + worm gearbox (产品类型)
审核			PG10K28-KW1317+LG1598K20 (产品型号)
批准		未注线性与角度尺寸公差: GB/T1804-m eqv ISO 2768-1:m	Tsinglin Micro Motors Limited
日期			

Worm and Worm Gear Parameter Table

Parameter	Worm	Worm Gear
Module	0.3	
Number of Threads / Teeth	1	20
Pressure Angle	180° C	180° C
Addendum Circle Diameter	4.5	6.6
Pitch Circle Diameter	3.9	6
Lead Angle	Right-hand 4.51°	
Worm Lead	0.942	-
Worm Pitch	0.942	-
Addendum Coefficient	1	1
Clearance Coefficient	0.25	0.25
Modification Coefficient	-	-
Center Distance	4.95	
Material	20 crmnti	
Accuracy Grade	GB/T 10095-2001 Grade 8	

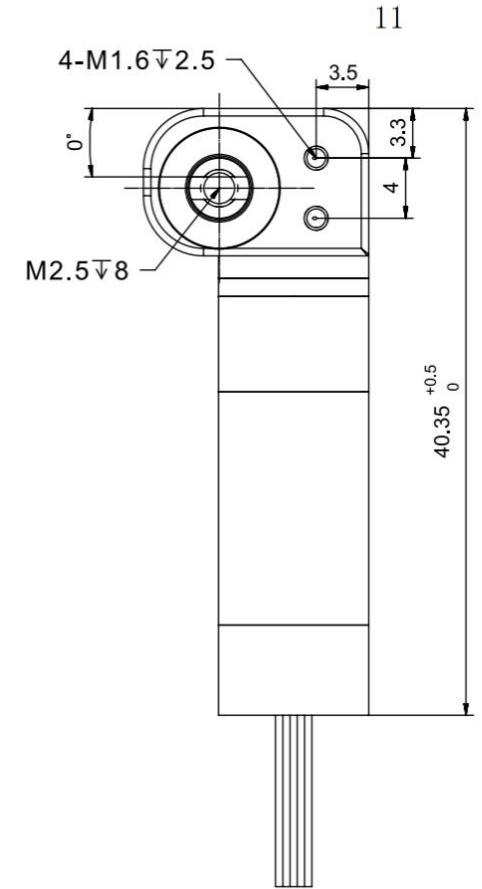
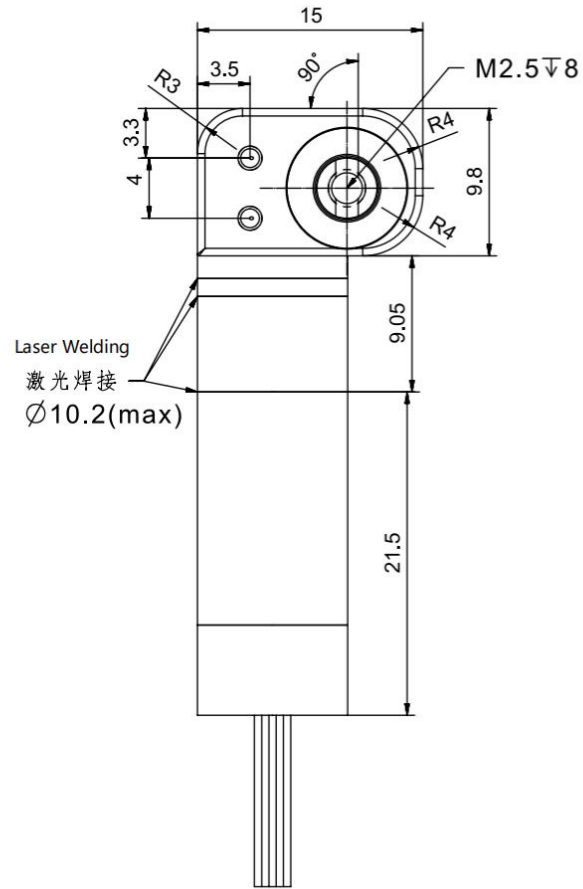
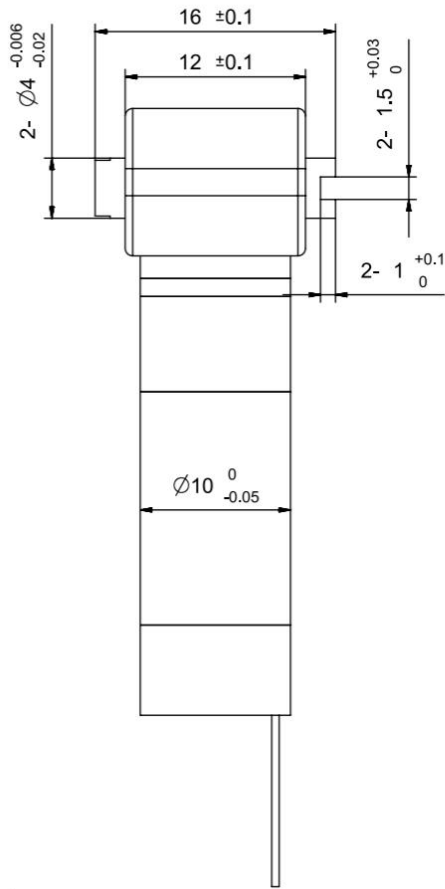

Motor Performance Parameters

Motor Type: Coreless Brushless Motor

(空心杯无刷电机)

Operating Voltage: 12V

No-Load Speed: 32,000 ± 10% RPM

No-Load Current: ≤ 0.15A

Rated Speed: 18,000 ± 10% RPM

Rated Torque: ≥ 10 g·cm

Rated Current: ≤ 0.5A

Number of Pole Pairs: 2 Pole Pairs (2对极)

Operating Temperature: -40°C to 85°C

Noise Level: ≤ 45 dB

Maximum Motor Efficiency: 75%

Geared Motor Performance Parameters

- Operating Voltage: 12V
- No-Load Speed: 55 ± 10% RPM
- No-Load Current: ≤ 0.2A
- Rated Speed: 35 ± 10% RPM
- Rated Torque: ≥ 800 g·cm
- Rated Current: ≤ 0.5A
- Operating Temperature: -40°C to 80°C
- Reduction Ratio: 1:560
- (Planetary 1:28, Worm & Worm Gear 1:20)
- Noise Level: ≤ 55 dB
- Gearbox Material: Pure Steel (Machined)

Encoder + Drive: Pin 1-4 Wires

Pin 1: VDD (Power Supply)

Pin 2: GND (Ground)

Pin 3: RXD (Receive Data)

Pin 4: TXD (Transmit Data)

设计

审核

批准

日期

第一视觉画法

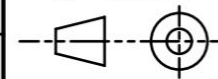

未注线性与角度尺寸公差：
GB/T 1804-m eqv
ISO 2768-1:m

10mm Planetary Gearbox + 10mm Coreless Brushless Motor + Integrated Encoder & Drive + Worm Gearbox

(产品类型)

PG10K28-KW1016+LG1598K20

(产品型号)

Tsinglin Micro Motors Limited

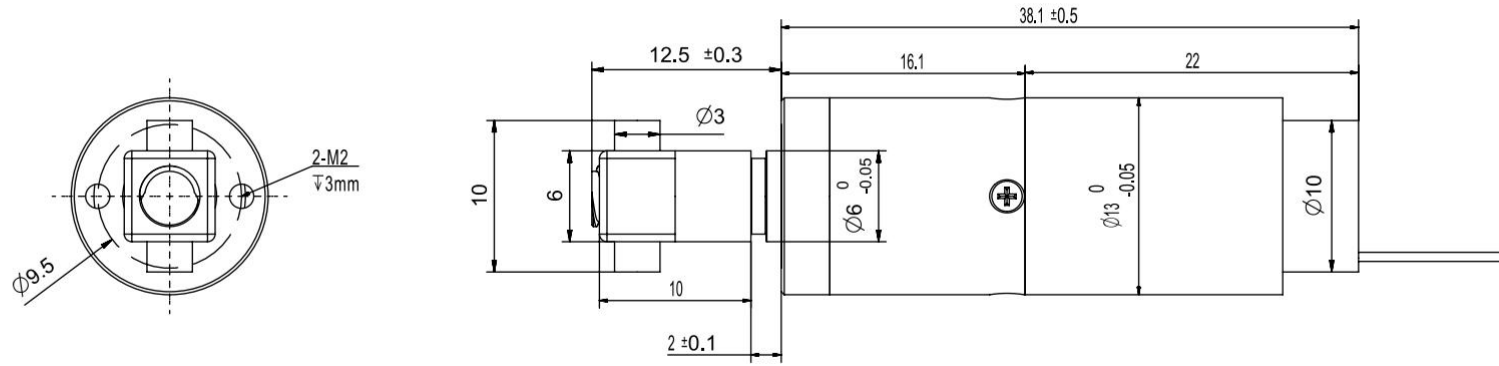

Lower lead screw nut, lead 2, diameter 4mm

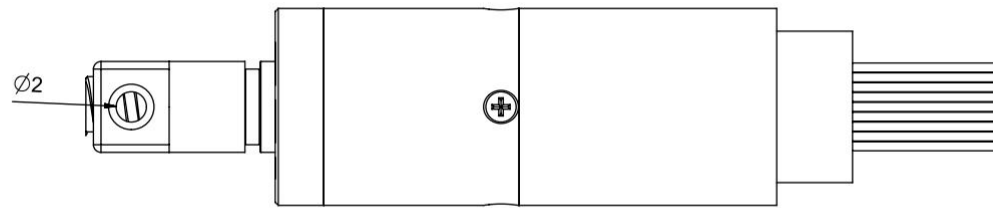

Encoder Wiring Sequence: PIN1-5

- pin1 - GND (Black)
- pin2 - VCC (Red)
- pin3 - A+ (Single-ended) (Yellow)
- pin4 - B+ (Single-ended) (Green)
- pin5 - Z+ (Single-ended) (Blue)

Note: Magnetic encoder, digital output, 3 channels, 1024 PPR

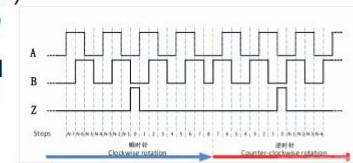

Coreless Brushless Motor

Wiring Sequence: PIN1-3

- pin1 - U (White)
- pin2 - V (Yellow)
- pin3 - W (Blue)

Motor Performance Parameters:

- 1.Motor Type:Coreless Brushless Motor
- 2.Operating Voltage:12V
- 3.No-load Speed:25000±10%RPM
- 4.No-load Current:≤0.2A
- 5.Load Speed:18000±10%RPM
- 6.Load Torque:≥15g.cm
- 7.Load Current:≤0.8A
- 8.Stall Torque:≥100g.cm
- 9.Pole Pairs:2 Pole Pairs
- 10.Operating Temperature:-40-85°C
- 11.Noise:≤45DB
- 12.Motor Maximum Efficiency:75%

Gearmotor Performance Parameters:

- 1.Operating Voltage:12V
- 2.No-load Speed:1000±10%RPM
- 3.No-load Current:≤0.3A
- 4.Load Speed:720±10%RPM
- 5.Load Torque:≥220g.cm
- 6.Load Current:≤1A
- 7.Operating Temperature:-40-85°C
- 8.Reduction Ratio:1:25
- 9.Noise:≤55DB
- 10.Gearbox Material:Pure Steel (Machined)
- 11.Geared motors should not be subjected to frequent impacts or stalling during operation.

设计		第一视觉画法	13mm Planetary Gearbox + 13mm Coreless Brushless Motor+T-type lead screw + Encoder (Product Type)
审核			TSL-PG13K25-KW1317-SG04+MA1024 (Product Model)
批准		未注线性与角度尺寸公差:	
日期	2025.11.05	GB/T1804-m eqv ISO 2768-1:m	Tsinglin Micro Motors Limited

Encoder Lead Wires: 28 AWG

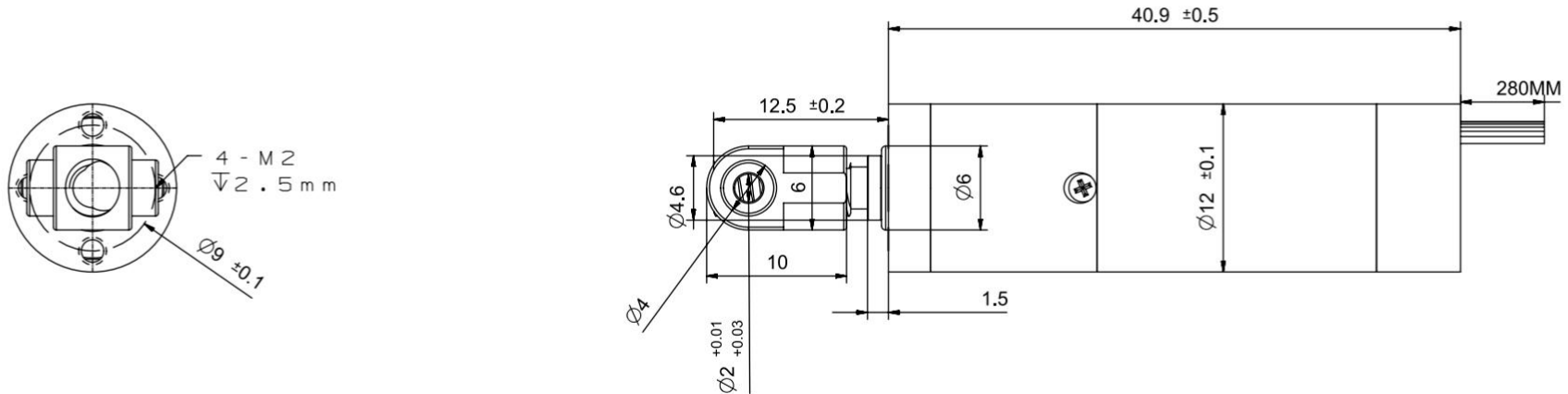

T-Shaped Lead Screw Parameters

1. Lead Screw Material: SUS303 (Stainless Steel)
2. Diameter: 4.0 (0, -0.05) mm (Tolerance: +0 / -0.05 mm)
3. Number of Starts: 1 start
4. Pitch: 1.5 mm
5. Thread Direction: Right-hand (RH)

The lead screw and nut are custom-matched by the same manufacturer; the axial backlash (play) between the lead screw and nut is < 0.05 mm.

Coreless Brushed Motor

Motor Pinout (1 - 2):

Positive (+): Red

Negative (-): Black

Encoder Pinout (1 - 4):

5V: White

GND: Yellow

A+: Green

B+: Blue

Magnetic encoder, 512 PPR (Pulses Per Revolution), 2 Channels

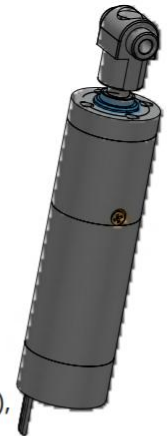

Motor Performance Parameters

1. Motor Type: Coreless Brushed Motor
2. Operating Voltage: 9 V
3. No-Load Speed: 24000 ± 10 RPM
4. No-Load Current: ≤ 0.1 A
5. Load Speed: 20000 ± 10 RPM
6. Load Torque: ≥ 15 g·cm
7. Load Current: ≤ 0.3 A
8. Pole Pairs: 1 pole pair (2 poles)
9. Operating Temperature: -20 to 80°C
10. Noise: ≤ 45 DB
11. Maximum Motor Efficiency: 75%

Geared Motor Performance Parameters

1. Operating Voltage: 9V
2. No-Load Speed: 665 ± 10% RPM
3. No-Load Current: ≤ 0.15A
4. Load Speed: 555 ± 10% RPM
5. Load Torque: ≥ 0.4 kgf·cm
6. Load Current: ≤ 0.4A
7. Operating Temperature: -20 to 80°C
8. Reduction Ratio: 1:36
9. Noise: ≤ 60dB (at a distance of 30cm)
10. Gearbox Backlash: ≤ 1.5 degrees
11. Gearbox Material: Pure Steel (Machined)

This product has a large stall torque, and stall operation is not recommended.

设计		第一视觉画法 	12 mm Planetary Gearbox + 12 mm Coreless Brushed Motor Incremental Encoder (产品类型)
审核			TSL-12P1220R-36+MA512-17.2 (产品类型)
批准		未注线性与角度尺寸公差： GB/T1804-m eqv ISO 2768-1:m	Tsinglin Micro Motors Limited
日期	2025.12.20		

Worm and Worm Gear Parameter Table		
	Worm	Worm Gear
Module	0.4	
Pressure Angle	1	20
Tip Diameter	5	8.8
Reference Diameter	4.2	8
Lead Angle	Right-hand 5.44°	
Worm Lead	1.257	-
Worm Pitch	1.257	-
Addendum Coefficient	1	1
Clearance Coefficient	0.25	0.25
Modification Coefficient	-	-
Transmission Center Distance	6.1	
Material	SUS416	20crmnti
Accuracy Class	GB/T 10095-2001-8级	

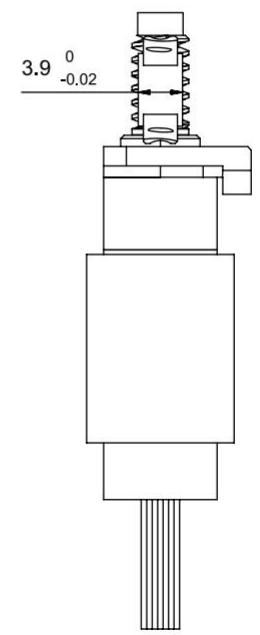
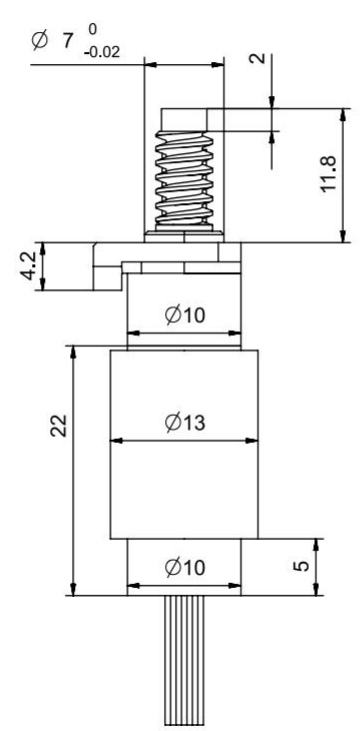
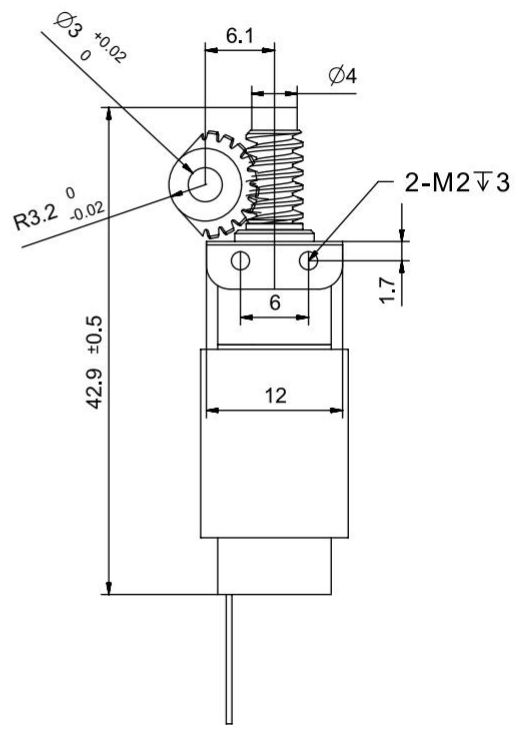

Motor Performance Parameters:

- Motor Type: Coreless Brushless Motor
- Operating Voltage: 12V
- No-load Speed: 25000±10%RPM
- No-load Current: ≤0.4A
- Load Speed: 18000±10%RPM
- Load Torque: ≥15g.cm
- Load Current: ≤1A
- Stall Torque: ≥100g.cm
- Pole Pairs: 2 Pole Pairs
- Operating Temperature: -40-85°C
- Weight: ≤30g
- Noise: ≤45DB
- Motor Maximum Efficiency: 75%

Gearmotor Performance Parameters:

- Operating Voltage: 12V
- No-load Speed: 45±10%RPM
- No-load Current: ≤0.5A
- Rated Speed: 30±10%RPM
- Rated Torque: ≥2500g.cm
- Rated Current: ≤1.2A
- Operating Temperature: -40-80°C
- Reduction Ratio: 1:560
(Planetary Stage 1:28, Worm and Worm Gear Stage 1:20)
- Noise: ≤55DB
- Gearbox Material: Pure Steel
(Machined)

Coreless Brushless Motor
Wiring Sequence: PIN1-3
pin1 - U
pin2 - V
pin3 - W

设计		第一视觉画法 	10mm Planetary Gearbox + 13mm Coreless Brushless Motor+Worm Gear Reducer + Drive (Product Type)
审核			TSL-PG10K28-KW1317+LG04M20Z (Module) (Product Model)
批准		未注线性与角度尺寸公差： GB/T 1804-m eqv ISO 2768-1:m	Tsinglin Micro Motors Limited
日期	2025.11.22		

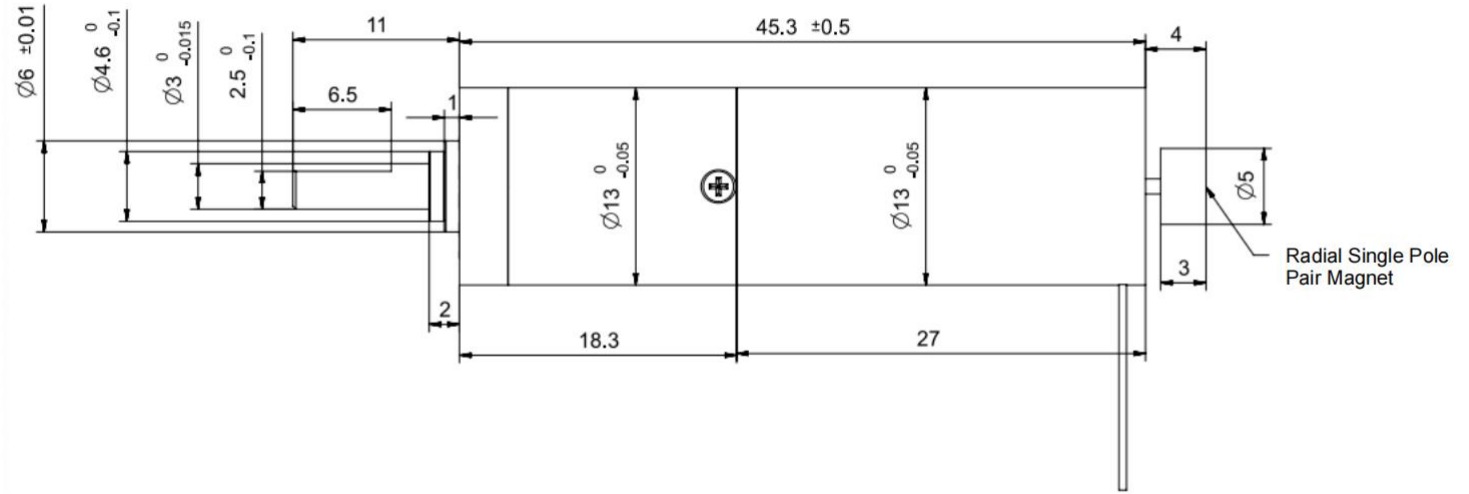
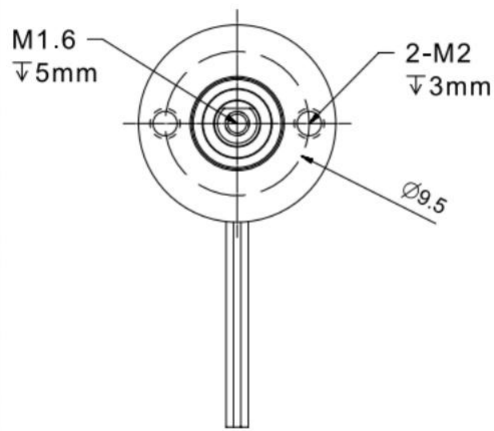

Coreless Brushless Motor

Wiring Sequence: PIN1-3

pin1 - U (White)

pin2 - V (Yellow)

pin3 - W (Blue)

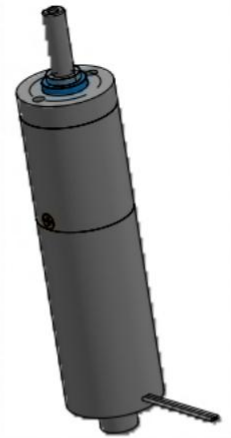

Motor Performance Parameters:

Motor Type: Coreless Brushless Motor

1. Operating Voltage: 12V
2. No-load Speed: 25000 ±10% RPM
3. No-load Current: ≤0.4A
4. Load Speed: 20000 ±10% RPM
5. Load Torque: ≥60 g·cm
6. Load Current: ≤0.8A
7. Stall Torque: >100 g·cm
8. Pole Pairs: 2
9. Operating Temperature: -40~85°C
10. Noise: ≤45 dB
11. Maximum Motor Efficiency: 75%

Gear Motor Performance Parameters:

1. Operating Voltage: 12V
2. No-load Speed: 200 ±10% RPM
3. No-load Current: ≤0.5A
4. Load Speed: 80 ±10% RPM
5. Load Torque: ≥0.4 N·m
6. Load Current: ≤1A
7. Operating Temperature: -40~80°C
8. Gear Ratio: 1:125
9. Noise: ≤55 dB
10. Gearbox Material: Solid Steel (Machined)

设计		第一视觉画法 	13mm Planetary Gearbox + 13mm Coreless Brushless Motor (Product Type)
审核			TSL-PG13K125-KW1327 (Product Model)
批准		未注线性与角度尺寸公差: GB/T1804-m eqv ISO 2768-1:m	Tsinglin Micro Motors Limited
日期	2025.08.08		

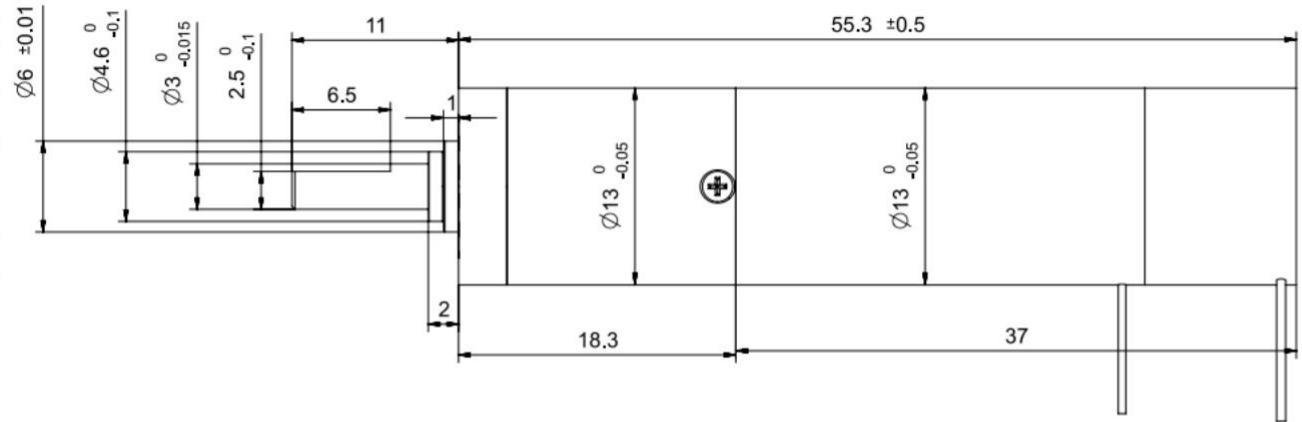
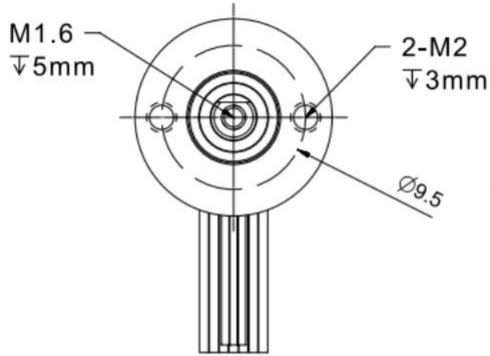

Brushless Coreless Motor

Wiring Sequence: PIN1-3

pin1 - U (White)

pin2 - V (Yellow)

pin3 - W (Blue)

Encoder Wiring Sequence: PIN1-5

pin1 - GND (Black)

pin2 - VCC (Red)

pin3 - A+ (Single-ended) (Yellow)

pin4 - B+ (Single-ended) (Green)

pin5 - Z+ (Single-ended) (Blue)

Note: Magnetic encoder, digital output, 3 channels, 1024 PPR

Motor Performance Parameters:

- 1.Motor Type: Brushless Coreless Motor
- 2.Operating Voltage: 12V
- 3.No-load Speed: 25000 ±10% RPM
- 4.No-load Current: ≤0.4A
- 5.Load Speed: 20000 ±10% RPM
- 6.Load Torque: ≥60 g·cm
- 7.Load Current: ≤0.8A
- 8.Stall Torque: >100 g·cm
- 9.Pole Pairs: 2
- 10.Operating Temperature: -40~85°C
- 11.Noise: ≤45 dB
- 12.Maximum Motor Efficiency: 75%

Gear Motor Performance Parameters:

- 1.Operating Voltage: 12V
- 2.No-load Speed: 200 ±10% RPM
- 3.No-load Current: ≤0.5A
- 4.Load Speed: 80 ±10% RPM
- 5.Load Torque: ≥0.4 N·m
- 6.Load Current: ≤1A
- 7.Operating Temperature: -40~80°C
- 8.Gear Ratio: 1:125
- 9.Noise: ≤55 dB
- 10.Gearbox Material: Solid Steel (Machined)

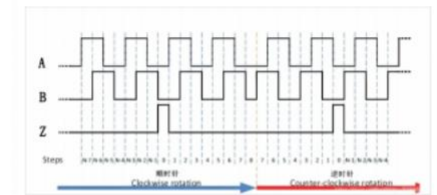

设计		第一视觉画法 	13mm Planetary Gearbox + 13mm Coreless Brushless Motor+Magnetic Encoder (Product Type)
审核			TSL-PG13K125-KW1327+MA1024 (Product Model)
批准		未注线性与角度尺寸公差： GB\T1804-m eqv ISO 2768-1:m	Tsinglin Micro Motors Limited
日期	2025.12.22		

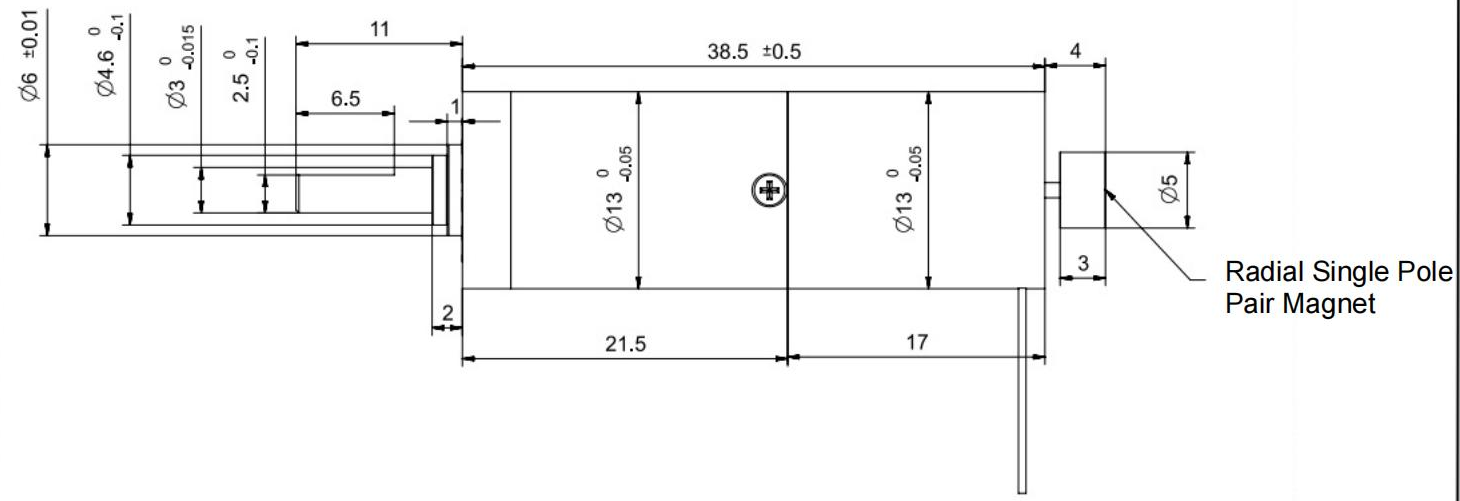
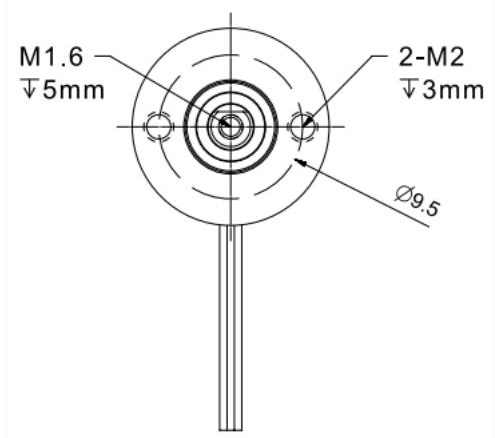

Coreless Brushless Motor

Wiring Sequence: PIN1-3

- pin1 - U (White)
- pin2 - V (Yellow)
- pin3 - W (Blue)

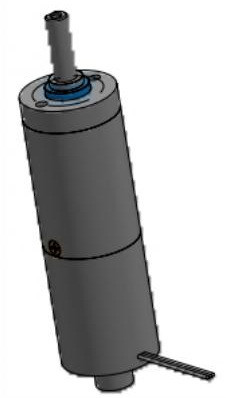

Motor Performance Parameters:

- 1.Motor Type: Coreless Brushless Motor
- 2.Operating Voltage: 12V
- 3.No-load Speed: 25000 ±10% RPM
- 4.No-load Current: ≤0.4A
- 5.Load Speed: 20000 ±10% RPM
- 6.Load Torque: ≥40 g·cm
- 7.Load Current: ≤0.8A
- 8.Stall Torque: >100 g·cm
- 9.Pole Pairs: 2
- 10.Operating Temperature: -40~85°C
- 11.Noise: ≤45 dB
- 12.Maximum Motor Efficiency: 75%

Gear Motor Performance Parameters:

- 1.Operating Voltage: 12V
- 2.No-load Speed: 90 ±10% RPM
- 3.No-load Current: ≤0.5A
- 4.Load Speed: 80 ±10% RPM
- 5.Load Torque: ≥0.7 N·m
- 6.Load Current: ≤1A
- 7.Operating Temperature: -40~80°C
- 8.Gear Ratio: 1:256
- 9.Noise: ≤55 dB
- 10.Gearbox Material: Solid Steel (Machined)

设计		第一视觉画法
审核		
批准		未注线性与角度尺寸公差： GB\T1804-m eqv ISO 2768-1:m
日期	2025.08.08	

13mm Planetary Gearbox + 13mm Coreless Brushless Motor (Product Type)
TSL-PG13K256-KW1317 (Product Model)
Tsinglin Micro Motors Limited

Worm and Worm Gear Parameter		
	Worm	Worm Gear
Module	0.4	
Number of Starts/Teeth	1	20
Pressure Angle	20°	20°
Addendum Circle Diameter	5	8.8
Pitch Circle Diameter	4.2	8
Lead Angle	右旋 5.44°	
worm lead	1.257	-
worm pitch	1.257	-
Addendum Coefficient	1	1
Clearance Coefficient	0.25	0.25
Modification Coefficient	-	-
center distance	6.1	
Material	20crmnti	SUS416
Accuracy Grade	GB/T 10095-2001-8级	

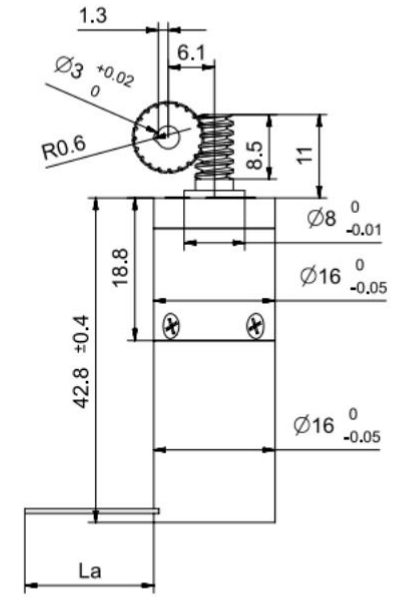
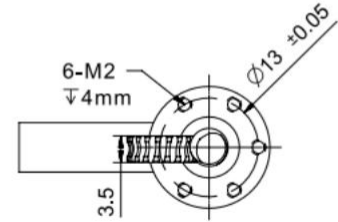

FPC Cable Length (La): 90 mm

Pin Number Definition
 pin1-Ha
 pin2-Hb
 pin3-Hc
 pin4-3.3V
 pin5-GND

 pin6+7-U

 pin8+9-V

 pin10+11-W
 pin12-Thermistor

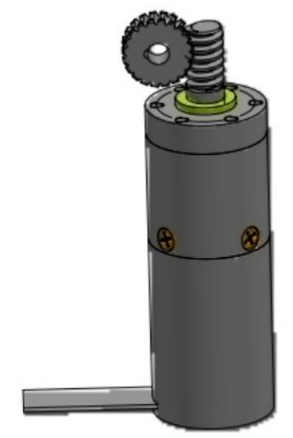

Motor Performance Parameters

- Motor Type: Coreless brushless motor
- Operating Voltage: 12 V
- No-load Speed: 35000 ± 10% RPM
- No-load Current: ≤ 0.4 A
- Rated Speed: 18000 ± 10% RPM
- Rated Torque: ≥ 70 g·cm
- Rated Current: ≤ 2 A
- Stall Torque: ≥ 200 g·cm
- Stall Current: ≤ 6 A
- Pole Pairs: 1 pair
- Operating Temperature: -40 - 80 °C
- Noise: ≤ 45 dB
- Maximum Motor Efficiency: 75%

Gear Motor Performance Parameters

- Operating Voltage: 12 V
- No-load Speed: 60 ± 10% RPM
- No-load Current: ≤ 0.4 A
- Rated Speed: 30 ± 10% RPM
- Rated Torque: ≥ 2 N·m
- Rated Current: ≤ 2 A
- Stall Torque: ≥ 5 N·m
- Operating Temperature: -40 - 80 °C
- Reduction Ratio: 1:580 (Planetary: 1:29; Worm Gear: 1:20)
- Noise: ≤ 55 dB
- Gearbox Material: Pure copper (machined)

版本	变更日期	变更内容
A 1	2025.04.10	Changed worm shaft and output shaft to be integrated
A 2	2025.04.11	Changed overall machine length and worm shaft length
设计		
审核		
批准		
日期	2025.04.10	

第一视觉画法

未注线性与角度尺寸公差：
 GB/T 1804-m eqv
 ISO 2768-1:m

16mm Planetary Gearbox + 16mm Coreless Brushless Motor + Worm Gear Output (Product Type)
 PG16K29-KW1624+LG04K20 (Product Model)
 Tsinglin Micro Motors Limited

Worm and Worm Gear Parameter		
	Worm	Worm Gear
Module	0.4	
Number of Starts/Teeth	3	20
Pressure Angle	20°	20°
Addendum Circle Diameter	5	8.8
Pitch Circle Diameter	4.2	8
Lead Angle	Right-hand 5.95°	
Addendum Coefficient	1	1
Clearance Coefficient	0.25	0.25
Modification Coefficient	-	-
Material	20crmnti	SUS416
Accuracy Grade	GB/T 10095-2001, Grade 8	

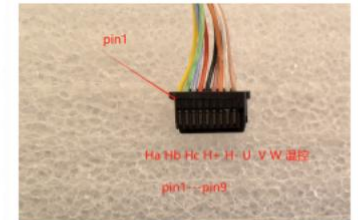
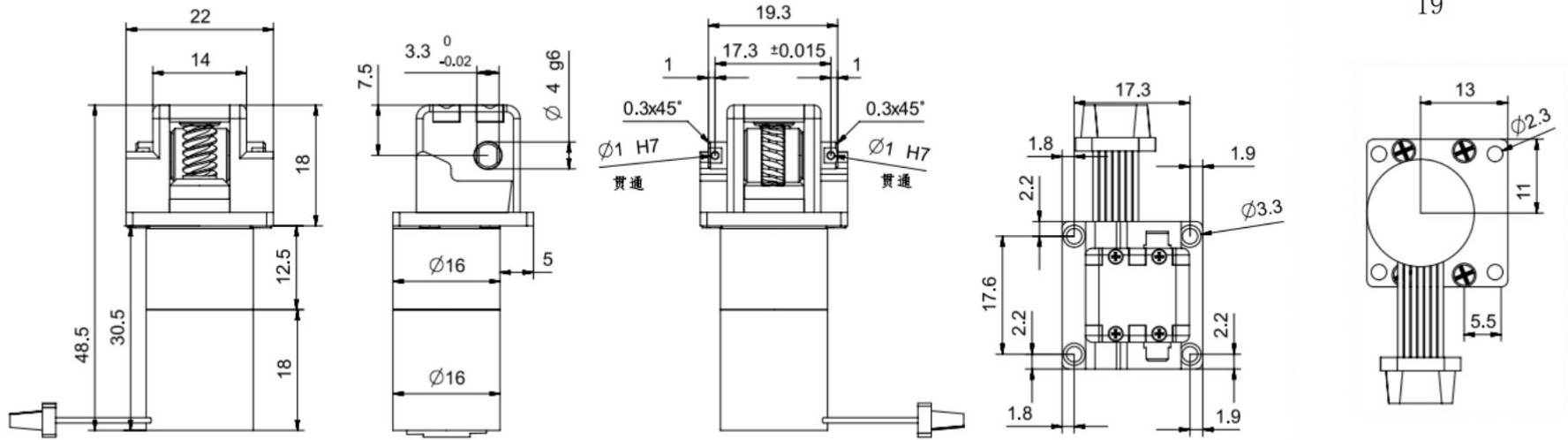

Terminal Model:KW30-10P-1C(800)

Wiring Sequence:1-9

- pin1-HALLA
- pin2-HALLB
- pin3-HALLZ
- pin4-3.3V
- pin5-GND
- pin6-motor U
- pin7-motor V
- pin8-motorW
- pin9-Temp.Ctrl.

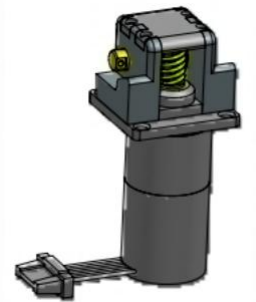

Motor Performance Specifications:

- 1.Motor Type:Coreless Brushless Motor
- 2.Operating Voltage:12V
- 3.No-load Speed:32000±10%RPM
- 4.No-load Current:≤0.5A
- 5.Load Speed:28000±10%RPM
- 6.Load Torque:≥3mNm
- 7.Load Current:≤2A
- 8.Number Of Pole Pairs:2 pole pairs
- 9.Operating Temperature:-40 to 85°C
- 10.Noise Level:≤45DB
- 11.Maximum Motor Efficiency:75%

Reducer Motor Performance Specifications:

- 1.Operating Voltage:12V
- 2.No-load Speed:35±10%RPM
- 3.No-load Current:≤0.5A
- 4.Load Speed:30±10%RPM
- 5.Load Torque:≥1Nm
- 6.Load Current:≤2A
- 7.Operating Temperature:-40 to 85°C
- 8.Gear Reduction Ratio:1:853 (Planetary:1:128,Worm Gear:1:6.67)
- 9.Noise Level:≤55DB
- 10.Gearbox Backlash:≤1.5 degree
- 11.Gearbox Material:Pure Copper (Machined)

版本	变更日期	变更内容
A 1	2025.03.22	Change the worm gear and output shaft to an integrated design
设计		
审核		
批准		
日期	2025.04.30	

第一视觉画法

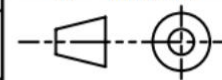

未注线性与角度尺寸公差:

GB\T1804-m eqv
ISO 2768-1:m

16mm Planetary Gearbox+16mm Coreless Brushless Motor+worm gear reverse output (Product Type)

TSL-PG16K128-KW1618+ LG04M20Z (Thumb Grasp Motor Module) (Product Model)

Tsinglin Micro Motors Limited

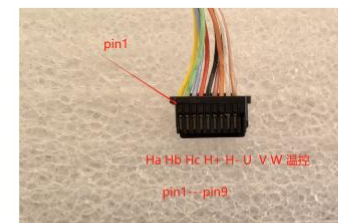
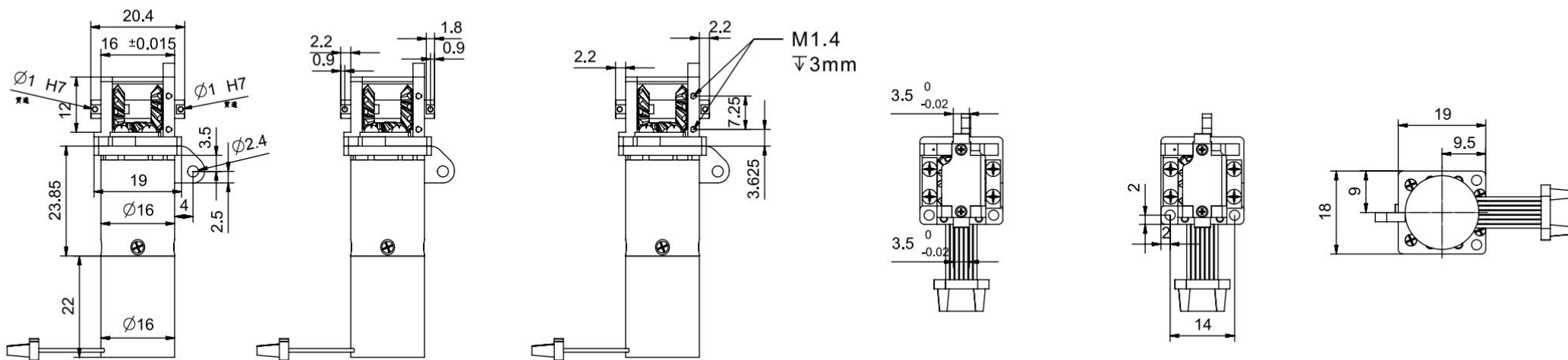

Connector Model: KW30-10P-1C (800)

Wire Sequence (Pins 1-9):
Pin Number Definition

- pin1 HALLA
- pin2 HALLB
- pin3 HALLZ
- pin4 3.3V
- pin5 GND
- pin6 Motor U
- pin7 Motor V
- pin8 Motor W
- pin9 Motor Thermistor



Motor Performance Parameters

- 1.Motor Type: Coreless brushless motor
- 2.Operating Voltage: 12 V
- 3.No-load Speed: 20000 ± 10% RPM
- 4.No-load Current: ≤ 0.15 A
- 5.Rated Speed: 18000 ± 10% RPM
- 6.Rated Torque: ≥ 25 g·cm
- 7.Rated Current: ≤ 0.5 A
- 8.Stall Torque: ≥ 260 g·cm
- 9.Stall Current: ≤ 3 A
- 10.Pole Pairs: 1 pair
- 11.Operating Temperature: -40 - 80 °C
- 12.Weight: ≤ 50 g
- 13.Noise: ≤ 45 dB
- 14.Maximum Motor Efficiency: 75%a

Gear Motor Performance Parameters

- 1.Operating Voltage: 12 V
- 2.No-load Speed: 50 ± 10% RPM
- 3.No-load Current: ≤ 0.2 A
- 4.Rated Speed: 45 ± 10% RPM
- 5.Rated Torque: ≥ 0.6 N·m
- 6.Rated Current: ≤ 0.6 A
- 7.Stall Torque: ≥ 5 N·m
- 8.Operating Temperature: -40 - 80 °C
- 9.Reduction Ratio: 1:388
- 10.Noise: ≤ 55 dB
- 11.Gearbox Backlash: ≤ 1.5°
- 12.Gearbox Material: Pure copper (machined)

版本	变更日期	变更内容
A 1	2025.03.22	Modified upper and lower brackets to enhance rigidity
设计		第一视觉画法
审核		
批准		未注线性与角度尺寸公差： GB/T1804-m eqv ISO 2768-1:m
日期	2025.04.30	

16mm Planetary Gearbox + 16mm Coreless Brushless Motor + 0.8 Modulus Bevel Gear Direction Change Output (Product Type)

PG16K388R-KW1622
+SC08M12Z (Right-hand Wrist Motor Module) (Product Model)

Tsinglin Micro Motors Limited

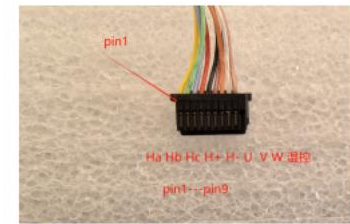
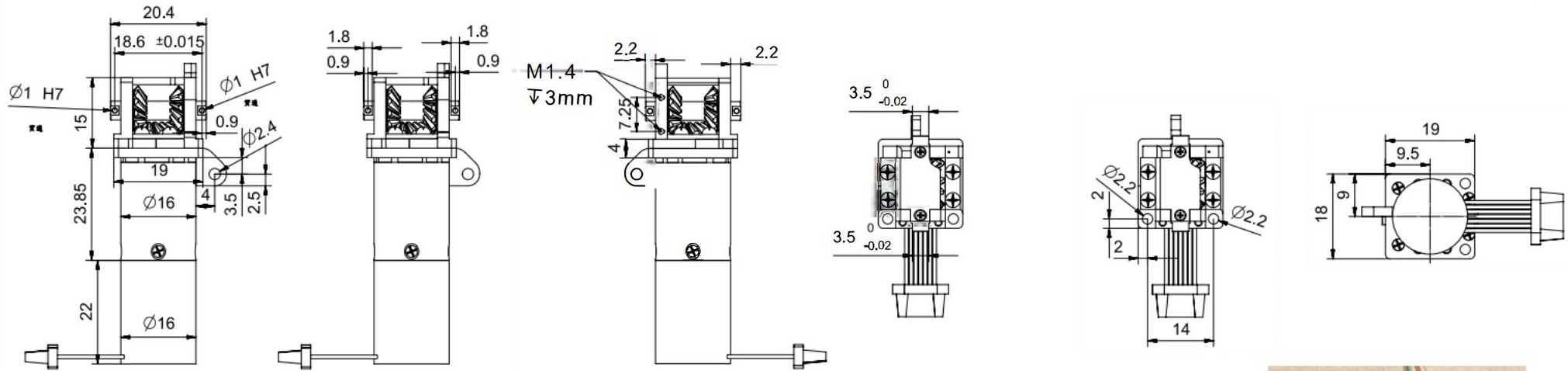

Connector Model: KW30-10P-1C(800)
 Wire Sequence (Pins 1-9):
 Pin Number Definition
 pin1 HALLA
 pin2 HALLB
 pin3 HALLZ
 pin4 3.3V
 pin5 GND
 pin6 Motor U
 pin7 Motor V
 pin8 Motor W
 pin9 Motor Thermistor

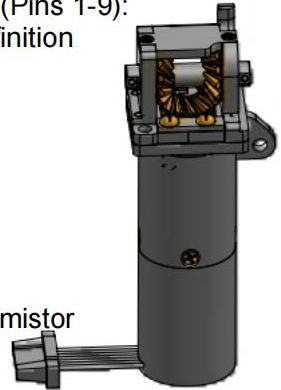

Motor Performance Parameters

- Motor Type: Coreless brushless motor
- Operating Voltage: 12 V
- No-load Speed: 20000 ± 10% RPM
- No-load Current: ≤ 0.15 A
- Rated Speed: 18000 ± 10% RPM
- Rated Torque: ≥ 25 g·cm
- Rated Current: ≤ 0.5 A
- Stall Torque: ≥ 260 g·cm
- Stall Current: ≤ 3 A
- Pole Pairs: 1 pair
- Operating Temperature: -40 - 80 °C
- Weight: ≤ 50 g
- Noise: ≤ 45 dB
- Maximum Motor Efficiency: 75%

Gear Motor Performance Parameters

- Operating Voltage: 12 V
- No-load Speed: 50 ± 10% RPM
- No-load Current: ≤ 0.2 A
- Rated Speed: 45 ± 10% RPM
- Rated Torque: ≥ 0.6 N·m
- Rated Current: ≤ 0.6 A
- Stall Torque: ≥ 5 N·m
- Operating Temperature: -40 - 80 °C
- Reduction Ratio: 1:388
- Noise: ≤ 55 dB
- Gearbox Backlash: ≤ 1.5°
- Gearbox Material: Pure copper (machined)

版本	变更日期	变更内容
A 1	2025.03.22	Modified upper and lower brackets to enhance rigidity
设计		
审核		
批准		
日期	2025.04.30	



16mm Planetary Gearbox + 16mm Coreless Brushless Motor + 0.8 Modulus Bevel Gear
 Direction Change Output (Product Type)
 PG16K388L-KW1622 + SC08M12Z (Left-hand Wrist Motor Module) (Product Model)
 Tsinglin Micro Motors Limited

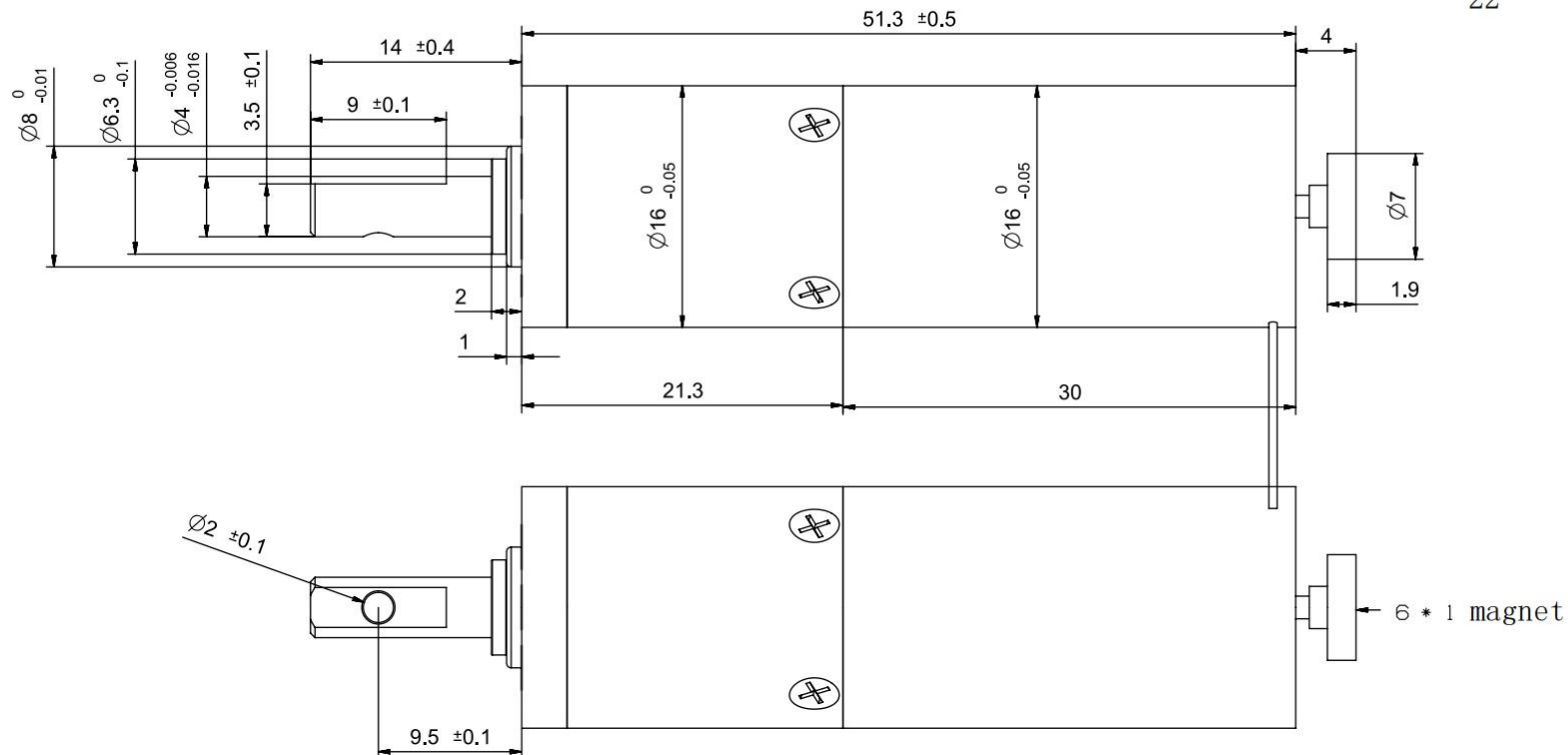
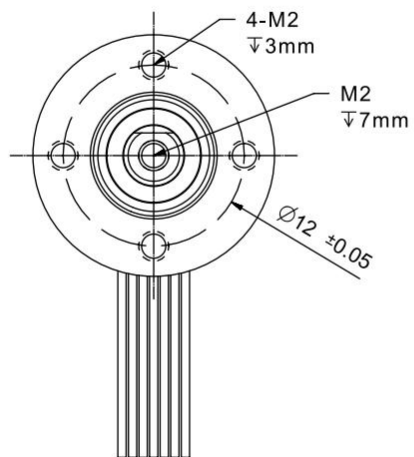

Coreless Brushless Motor
Hall Wiring Sequence: PIN1-8

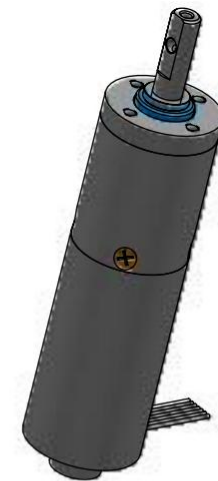

Motor Performance Parameters:

- Motor Type: Coreless Brushless Motor
- Operating Voltage: 12V
- No-load Speed: 26000 ±10% RPM
- No-load Current: ≤0.4A
- Rated Speed: 21000 ±10% RPM
- Rated Torque: ≥160 g·cm
- Rated Current: ≤2A
- Pole Pairs: 2
- Operating Temperature: -40~80°C
- Noise: ≤35 dB
- Maximum Motor Efficiency: 75%

Gear Motor Performance Parameters:

- Operating Voltage: 12V
- No-load Speed: 300 ±10% RPM
- No-load Current: ≤0.4A
- Rated Speed: 240 ±10% RPM
- Rated Torque: ≥0.8 N·m
- Rated Current: ≤2A
- Operating Temperature: -40~80°C
- Gear Ratio: 1:84
- Noise: ≤45 dB
- Gearbox Material: Solid Steel (Machined)

pin1 - U (White \ Thick)
pin2 - V (Yellow \ Thick)
pin3 - W (Blue \ Thick)
pin4 - +5V (Red)
pin5 - GND (Black)
pin6 - HALL_U (White)
pin7 - HALL_V (Yellow)
pin8 - HALL_W (Blue)

设计		第一视觉画法 	16mm Planetary Gearbox + 16mm Coreless Brushless Motor (Product Type)
审核			TSL-PG16K84-KW1630 (Product Model)
批准		未注线性与角度尺寸公差： GB/T1804-m eqv ISO 2768-1:m	Tsinglin Micro Motors Limited
日期	2025.02.25		

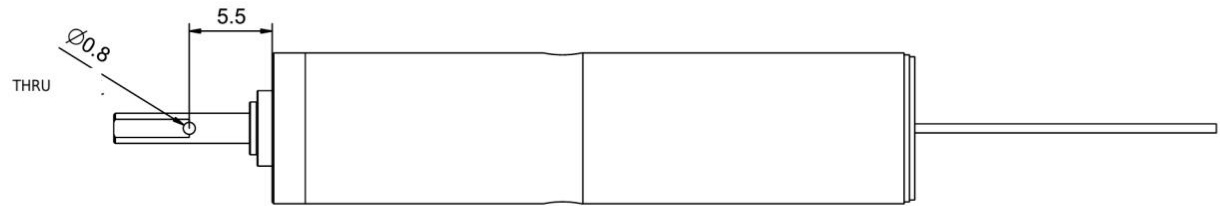
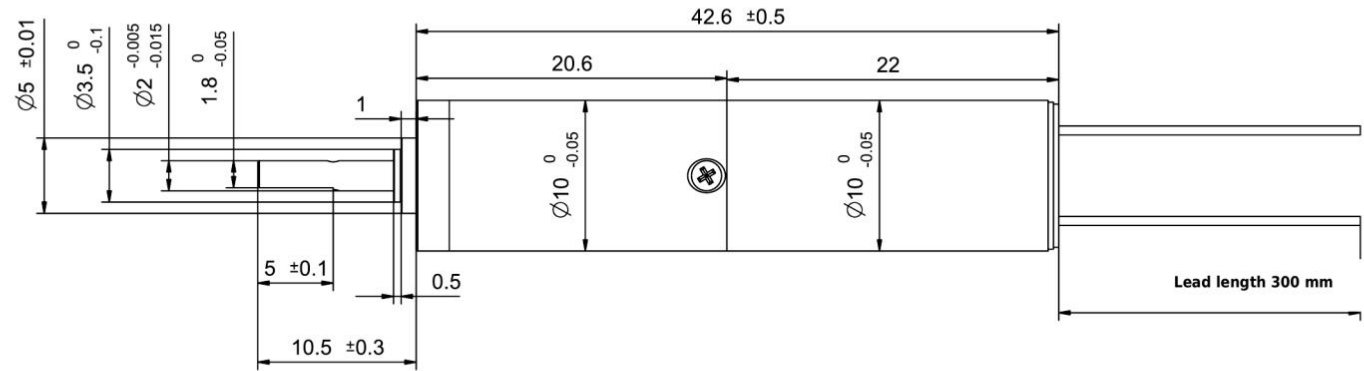
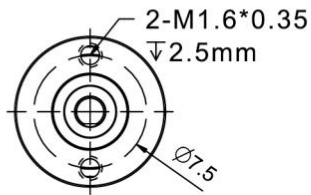

Motor Performance Parameters:

1. Motor type: coreless brushed motor
2. Working voltage: 12 V
3. No-load speed: 16700 +/- 10% RPM
4. No-load current: <=10 mA
5. Load speed: 13700 +/- 10% RPM
6. Load torque: >=7 g.cm
7. Load current: <=70 mA
8. Stall torque: >=30 g.cm
9. Stall current: <=1 A
10. Pole pairs: 1 pair
11. Operating temp.: -45 - 85 deg C
12. Noise: <=35 dB
13. Max motor efficiency: 75%

Gearmotor Performance Parameters:

1. Working voltage: 12 V
2. No-load speed: 51 +/- 10% RPM
3. No-load current: <=50 mA
4. Load speed: 42 +/- 10% RPM
5. Load torque: 0.15 N.m
6. Load current: <=170 mA
7. Operating temp.: -45 - 85 deg C
8. Gear ratio: 1:326
9. Noise: <=55 dB
10. Gearbox material: pure Cu (machined)

Motor wiring: PIN1-2
 pin1 - VCC red (positive)
 pin2 - GND black (negative)

Design		First-angle projection 	10 mm planetary gearbox + 10 mm coreless brushed motor <small>(Product type)</small>
Check			PG10K326-KS1022 (Round threaded hole) <small>(Product model)</small>
Approved		Unspecified linear & angular tolerances: GB\11804-m eqv ISO 2768-1:m	Tsinglin Micro Motors Limited
Date	2026.02.28		

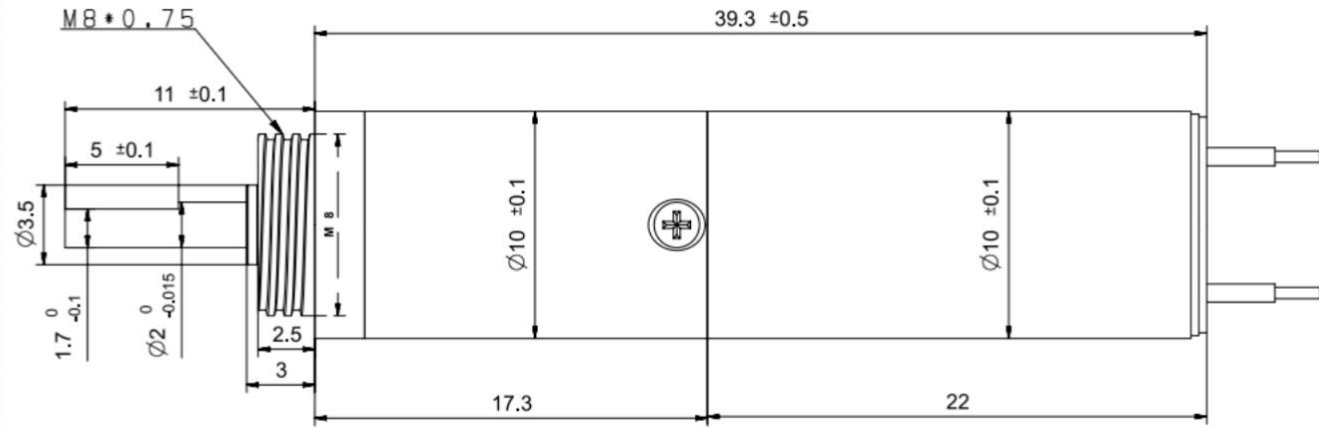
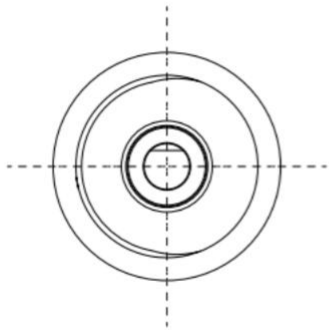

减速电机性能参数:

Coreless Gear Motor Data:

- 1、工作电压 (Volt): 4.5V
- 2、空载转速: 187 ± 10% RPM
- No Load Speed:
- 3、空载电流: ≤ 90mA
- No Load Current:
- 4、负载转速: 117 ± 10% RPM
- Load Speed:
- 5、负载力矩: ≥ 0.1NM
- Load Torque:
- 6、负载电流: ≤ 0.7A
- load Current:
- 7、工作温度: -20-85℃

- Temp:
- 9、噪音: ≤ 60DB (30CM)
- Noise:
- 10、减速箱背隙: ≤ 1.5度
- Gearbox Backlash
- 11、减速箱材质: 纯钢 (机加工)
- Raw Material:
- Steel (machined)

Brush Coreless motor

线序 (1-2):

Wire:

- 1、正极 VCC (+) 红色 RED
- 2、负极 GND (-) 黑色 BLACK



设计		第一视觉画法	10mm Coreless Brushed Motor with 10mm Planetary Gearbox
审核			(产品类型)
批准		未注线性与角度尺寸公差:	TSL-10P1022R-77
日期	2025.12.20	GB/T1804-m eqv ISO 2768-1:m	(产品型号) Tsinglin Micro Motors Limited

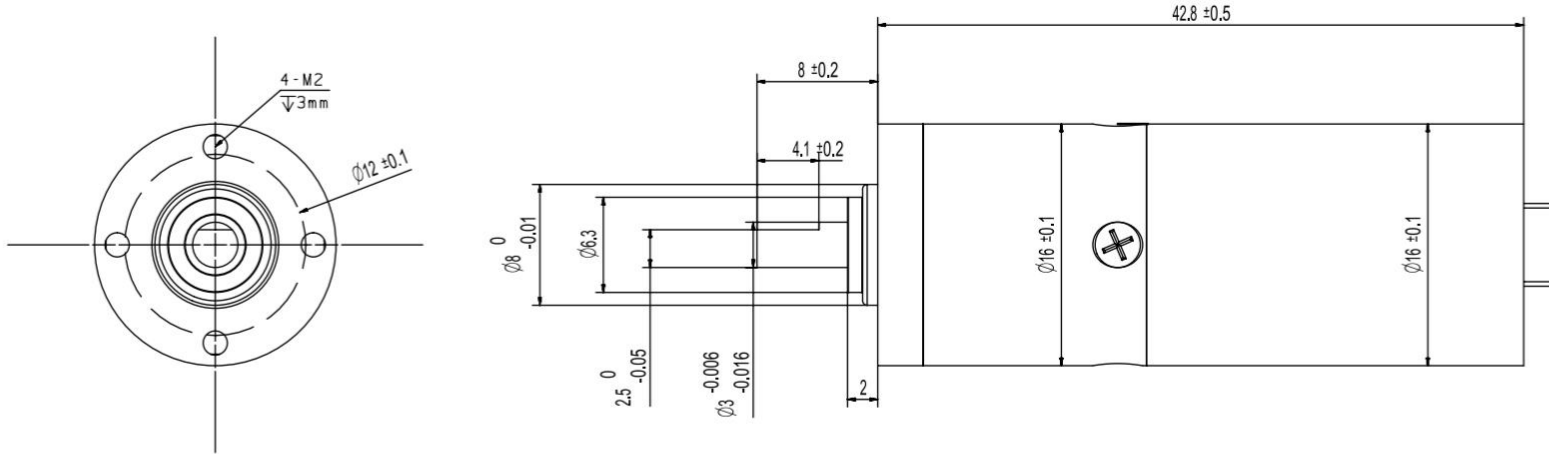

Motor Pinout (1 - 2)
 Positive (+): Red
 Negative (-): Black



Geared Motor Performance Parameters

1. Operating Voltage: 6V
2. No-Load Speed: 813 ± 10% RPM
3. No-Load Current: ≤ 0.15A
4. Load Speed: 586 ± 10% RPM
5. Load Torque: ≥ 0.05 N·m
6. Load Current: ≤ 1.4A
7. Operating Temperature: -20 to 80°C
8. Reduction Ratio: 1:16
9. Noise: ≤ 60dB
10. Gearbox Backlash: ≤ 1.5 degrees
11. Gearbox Material: Pure Steel
(Machined)

设计		第一视觉画法 	16 mm Planetary Gearbox + 16 mm Coreless Brushed Motor (产品类型)
审核			TSL-16P1625R-16 (产品型号)
批准		未注线性与角度尺寸公差： GB\T1804-m eqv ISO 2768-1:m	Tsinglin Micro Motors Limited
日期	2025.12.20		

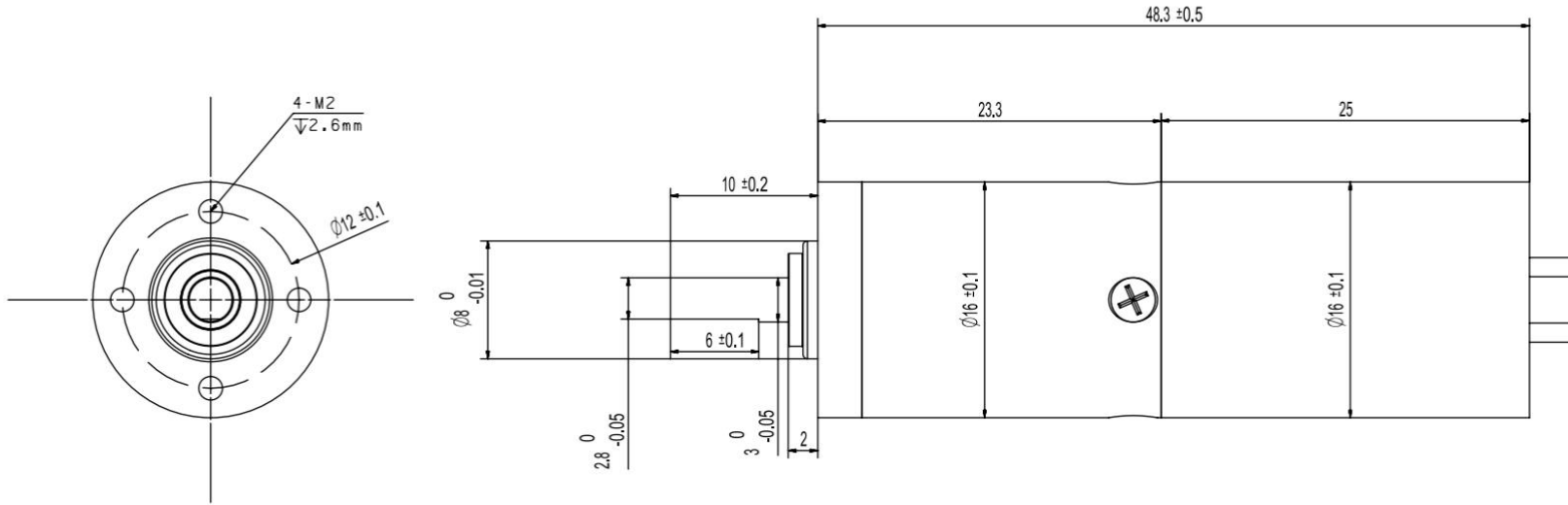

Motor Pinout (1 - 2)
 Positive (+): Red
 Negative (-): Black



Motor Performance Parameters

1. Motor Type: Coreless Brushed Motor
2. Operating Voltage: 12V
3. No-Load Speed: 13000 ± 10% RPM
4. No-Load Current: ≤ 0.1A
5. Load Speed: 9500 ± 10% RPM
6. Load Torque: ≥ 26 g·cm
7. Load Current: ≤ 0.2A
8. Pole Pairs: 1 pole pair (2 poles)
9. Operating Temperature: -40 to 85°C
10. Noise: ≤ 45dB
11. Maximum Motor Efficiency: 75%

Geared Motor Performance Parameters

1. Operating Voltage: 12V
2. No-Load Speed: 240 ± 10% RPM
3. No-Load Current: ≤ 0.2A
4. Load Speed: 180 ± 10% RPM
5. Load Torque: ≥ 0.1 N·m
6. Load Current: ≤ 0.25A
7. Operating Temperature: -40 to 85°C
8. Reduction Ratio: 1:53
9. Noise: ≤ 55dB (at a distance of 30cm)
10. Gearbox Backlash: ≤ 1.5 degrees
11. Gearbox Material: Pure Steel (Machined)

This product has a large stall torque, and stall operation is not recommended.

设计		第一视觉画法 	16 mm Planetary Gearbox +16mm Coreless Brushed Motor
审核			TSL-16P1625R-53 (产品型号)
批准		未注线性与角度尺寸公差： GB/T1804-m eqv ISO 2768-1:m	Tsinglin Micro Motors Limited
日期	2025.9.15		

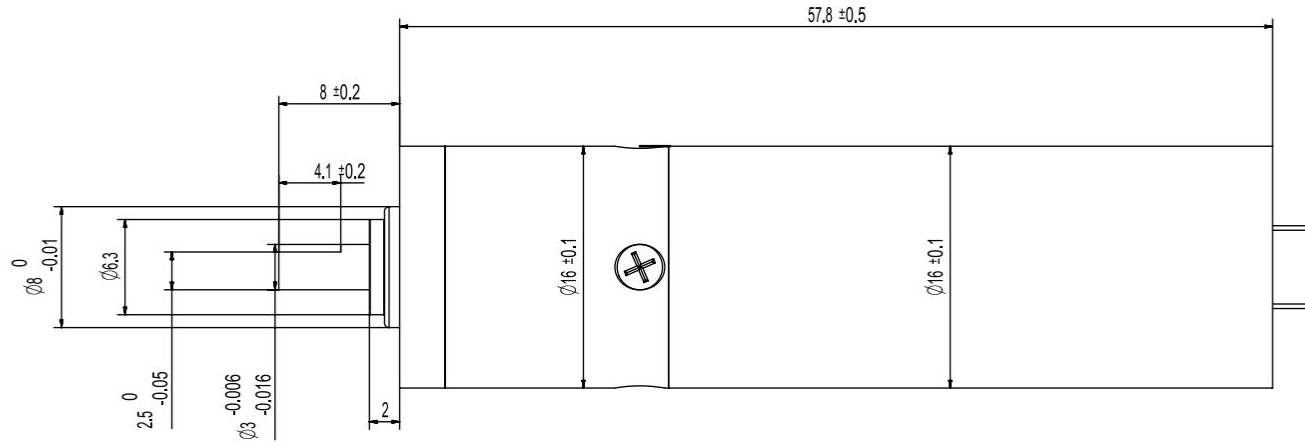
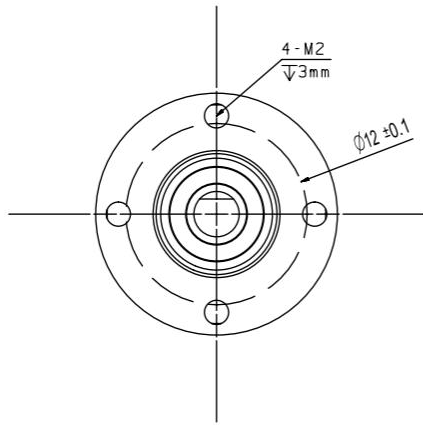

Motor Pinout (1 - 2)
 Positive (+): Red
 Negative (-): Black



Geared Motor Performance Parameters

1. Operating Voltage: 6V
2. No-Load Speed: 813 ± 10% RPM
3. No-Load Current: ≤ 0.18A
4. Load Speed: 680 ± 10% RPM
5. Load Torque: ≥ 0.1 N·m
6. Load Current: ≤ 2.4A
7. Operating Temperature: -20 to 80°C
8. Reduction Ratio: 1:16
9. Noise: ≤ 60dB
10. Gearbox Backlash: ≤ 1.5 degrees
11. Gearbox Material: Pure Steel
(Machined)

设计		第一视觉画法	16 mm Planetary Gearbox +16mm Coreless Brushed Motor
审核			(产品类型)
批准		未注线性与角度尺寸公差:	TSL-16P1640R-16
日期	2025.12.20	GB\T1804-m eqv ISO 2768-1:m	(产品型号) Tsinglin Micro Motors Limited